

# WHEEL RIM STRAIGHTENING MACHINE Model PO-22H

## Instruction Manual

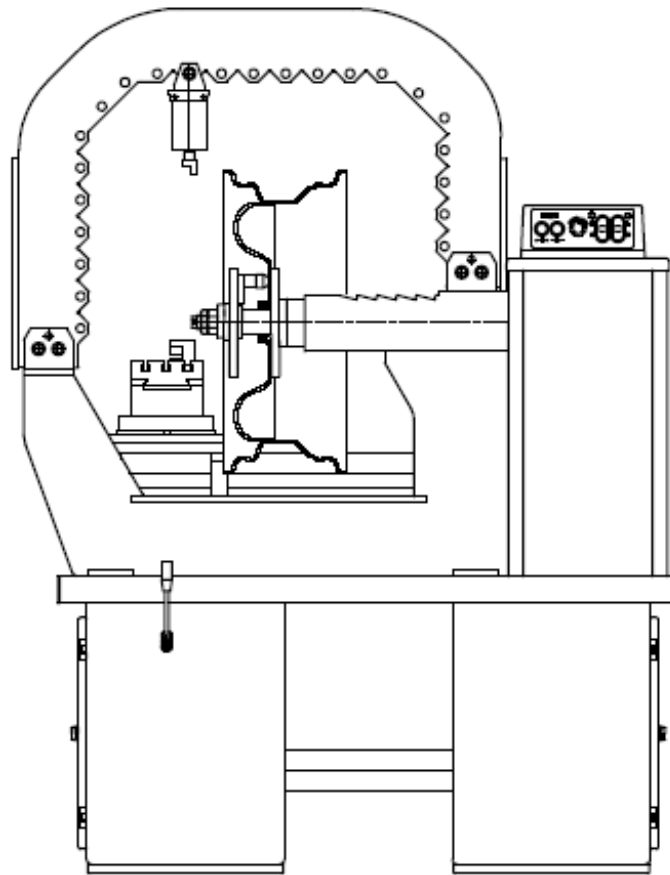

**“UNI-TROL” Co.Ltd.**

**Ul. Estrady 56**

**01-932 Warsaw, Poland**

**tel./fax (+4822) 817 94 22 & 834 90 13 (14)**

# Operation Manual

## WHEEL RIM STRAIGHTENING MACHINE Model PO-22H

Serial number

Production date

### MANUFACTURER:

**“UNI-TROL” Co.Ltd.**

**Ul. Estrady 56**

**01-932 Warsaw, Poland**

**tel./fax (+4822) 817 94 22 & 834 90 13 (14)**

## **TABLE OF CONTENTS**

- 1.0 INTRODUCTION**
- 2.0 OPERATORS' TRAINING**
- 3.0 TRANSPORTATION AND PACKAGING**
- 4.0 INSTALLATION REQUIREMENTS**
  - 4.1 PLACE OF INSTALLATION**
  - 4.2 ELECTRICAL CONNECTION**
- 5.0 INDUSTRIAL SAFETY**
  - 5.1 RULES FOR THE OPERATOR**
  - 5.2 SERVICE, REPAIRS AND SPARE PARTS EXCHANGE**
- 6. STORING**
- 7. SCRAPPING**
- 8. RECOMMENDATIONS AND WARNINGS CONCERNING OIL**
- 9. RECOMMENDATIONS ON FIRE-FIGHTING EQUIPMENT**
- 10.0 TECHNICAL DESCRIPTION**
  - 10.1 GENERAL INFORMATION**
  - 10.2 TECHNICAL DATA**
  - 10.3 ELECTRICAL SYSTEM**
  - 10.4 HYDRAULIC SYSTEM**
- 11.0 WHEEL RIM STRAIGHTENING MACHINE OPERATION**
  - 11.1 GENERAL PROTECTION INSTRUCTIONS**
  - 11.2 MOUNTING AND DEMOUNTING SYSTEM OPERATION**
  - 11.3 SENSOR**
  - 11.4 CORRECTION**
- 12.0 WHEEL RIM SPREADING DEVICE**
- 13.0 ACCESSORIES**
- 14.0 HEALTH AND SAFETY REGULATIONS**
- 15.0 ELECTRICAL SYSTEM SCHEME**
- 16.0 HYDRAULIC SYSTEM SCHEME**
- 17.0 PICTURE CATALOGUE OF SPARE PARTS**
- 18.0 DECLARATION OF CONFORMITY**

---

## **1. INTRODUCTION**

---

This operation manual is an integral part of the straightening machine for car wheel rims from 10" to 22" with a turning lathe. The remarks and recommendations included in this manual must be read carefully since they concern important instructions on the machine's operation and maintenance. The manual must be kept in a safe and easily accessible place.

The manufacturer or the distributor shall not be liable for any damages arising from not observing the instructions included in this manual.

The machine must be used according to its purpose. Any other application will be considered wrong and improper. The manufacturer or the distributor shall not be liable for any damages arising from improper, wrong or unreasonable use of the machine.

---

## **2. OPERATORS' TRAINING**

---

The machine must be operated only by authorised and specially trained personnel. The operators' training must be carried according to the manufacturer's instructions. This shall assure a high standard of the machine's operation and safety.

---

## **3. TRANSPORTATION AND PACKAGING**

---

Before transporting the machine packed, read the instructions on its packaging. Transportation must be carried with a fork lift. Check if the fork lift operator has got the necessary licence. After unpacking the machine, make sure there is a manual inside and check if the machine's subassemblies are complete with no visible damage. After unpacking the machine, the packaging must be put in a place which is not accessible for children or animals.

The machine is packed on a pallet and covered with the stretch foil or a cardboard box.

---

## **4. INSTALLATION REQUIREMENTS**

---

### 4.1 Place of installation

- a flat, solid, preferably concrete surface
- sufficient lighting (which is not flickering and eye-exhausting)
- roofed area protected from the outside weather conditions
- work place with the noise level lower than demanded
- work place in a clean place
- work place should be located far from other machines
- explosive, poisonous or corrosive materials must not be stored in the same place
- the operator has to see the whole machine and its surrounding during operation.  
Unauthorised persons or unnecessary objects must be kept out of the machine's work place.
- mains connection must be done by authorised personnel
- the machine must be located in such a way that the operator can access it from the front or from the back, not restricting his hands' movements, far from a wall or other machines.

## 4.2 ELECTRICAL CONNECTION

Connecting the machine to the power supply must be done by authorised personnel. The electric connection must correspond to the voltage taken by the machine, stamped on its rating support.

Connecting the machine to power supply requires the following parts:

- a separate electric switch which meets the safety regulations;
- a suitable circuit breaker;
- an effective grounding circuit which has been previously checked.

**Prohibited is a connection** the grounding wire to the gas or water supply pipes, telephone line or any other installation.

---

## 5. INDUSTRIAL SAFETY

---

The manufacturer shall not be liable for any damages arising from modifications to the machine which were not previously authorised. Removing or modifying the safety devices is not compliant with the European regulations.

### 5.1. RULES FOR THE OPERATOR

- The operator must avoid hazardous situations during work.
- In case the machine is working improperly, turn it off and call the customer service.
- Remove from the machine's surrounding all the items which may be hazardous during operation. Make sure there is no oil on the floor which may be hazardous for the operator.
- For protection from dust and other externals, the operator must wear a special clothing, goggles and protective gloves.
- During work you must take off your bracelets, rings, watches, and other loose decorations. The operators with long hair must tie it back so that they could work easily. The operator ought to equip a suitable shoes.

### 5.2. TECHNICAL SERVICE, REPAIRS AND SPARE PARTS EXCHANGE

- Servicing, maintenance work and spare parts exchange must be carried out by authorised personnel.
- Before any service work, disconnect the machine from the power supply.
- You must not use spare parts other than those supplied by the manufacturer.
- The machine's spare parts and accessories have to meet safety regulations.

---

## 6. STORING

---

If the machine is to be stored for a long time, it must be disconnected from the power supply, with the oil tank emptied, and covered to protect it from externals (dust, oil

mist etc.). The parts which might get damaged in case they dry out have to be lubricated.

---

## **7. SCRAPPING**

---

When the machine is going to be scrapped, all the electric and electrical parts as well as those made of plastic have to be disassembled, while the rest has to be scrapped as the steel scrap.

The electric wires can be scrapped as the copper scrap.

---

## **8. RECOMMENDATIONS AND WARNINGS CONCERNING OIL**

---

### ***Removing wasted oil***

Wasted oil must not be poured to sewage, ditches, drainage canals or water ways. It must be collected and brought to the oil waste utilization points.

### ***Oil leakage or spills***

Spilled oil must be wiped out by means of sand, ground or absorbent material. The leakage surface needs to be degreased by means of solvents to prevent vapour retention.

### ***Rules for oil use***

- Avoid a long-lasting contact of oil with your skin.
- Prevent forming of vapours or mist which evaporate to the atmosphere.
- Observe the following hygiene requirements:
  - avoid spilling with oil (wear special clothing, put protective covers on the equipment).
  - wash your hands often with soap and water; do not use any irritating cleaning materials or solvent which remove the protective layer from your epidermis of hands.
  - do not dry your hands with dirty or oiled cloths.
  - change the clothing which is soaked with oil, and put on a clean work clothing everyday.
  - do not smoke or eat with your hands oiled.
- Also the following preventive measures must be taken into account:
  - wear protective oil-resistant gloves.

### ***Oil: the first aid principles***

- Oil swallowing: Generally, no special treatment is required. Do not evoke vomiting to prevent breathing the oil vapours in or oil getting into the respiratory tract.
- Getting of oil into the respiratory tract: if, in case of reflexive vomiting, the oil gets into the respiratory tract, the injured person needs to be taken to hospital immediately.
- Breathing in the oil vapours: In case of breathing in the oil vapours or oil mist with high oil concentration, the injured person needs to be taken in the open air.
- Getting of oil in the eyes: Wash the eyes with water.
- Oiled skin: Wash your skin with soap and water.

---

## 9. RECOMMENDATIONS ON FIRE-FIGHTING EQUIPMENT

---

While choosing the right fire-extinguisher, follow the recommendations below:

### **Dry inflammable matters**

Water fire-extinguishers	<b>YES</b>
Foam fire-extinguishers	<b>YES</b>
Dry chemical fire-extinguishers	<b>YES*</b>
CO2 fire-extinguishers	<b>YES*</b>

**YES\*** use only when there is no better fire-extinguisher nearby and when the fire is modest.

### **Inflammable liquids**

Water fire-extinguishers	<b>NO</b>
Foam fire-extinguishers	<b>YES</b>
Dry chemical fire-extinguishers	<b>YES</b>
CO2 fire-extinguishers	<b>YES</b>

### **Electric devices**

Water fire-extinguishers	<b>NO</b>
Foam fire-extinguishers	<b>NO</b>
Dry chemical fire-extinguishers	<b>YES</b>
CO2 fire-extinguishers	<b>YES</b>

### **WARNING**

The above given recommendation are of a general character. These are general principles for fire-extinguishers' use. Detailed application of each kind of fire-extinguisher is provided by its manufacturer on customer's order.

---

## 10.0 TECHNICAL DESCRIPTION

---

### 10.1 GENERAL INFORMATION

The machine is designed to repair of faults 10"-22" steel and aluminium rims. The rim repair is carried out by means of the hydraulic piston supplied with the suitable shaped working tools.

The machine is supplied with a quick release hydraulic adapter to set the position and mount a rim securely.

Repairs are easy, and the time of repair does not exceed few minutes. The working end caps allow to fix a damaged rim in any place of its bend.

The straightening machine is supplied with:

- the working tools of different shapes to repair various deformations;
- a set of centring rings to repair rims with different diameters of central holes;
- a device to locate rim deformations;
- mounting mechanical pressures with regulated set bolts;
- a lever for preliminary rim straightening.

### 10.2 TECHNICAL DATA

rim diameters range	10"-22"
maximum pressure in the hydraulic system	16 MPa (160 bar)
power supply	3 x 400 V / 50 Hz
hydraulic pump motor	0.55 kW
drive motor	0.37 kW
noise level	< 70 dBa
weight	450 kg
straightening servo-motor's force	45 kN

### APPEARANCE

The machine's dimensions with the description of its main parts are presented in the figure 1.



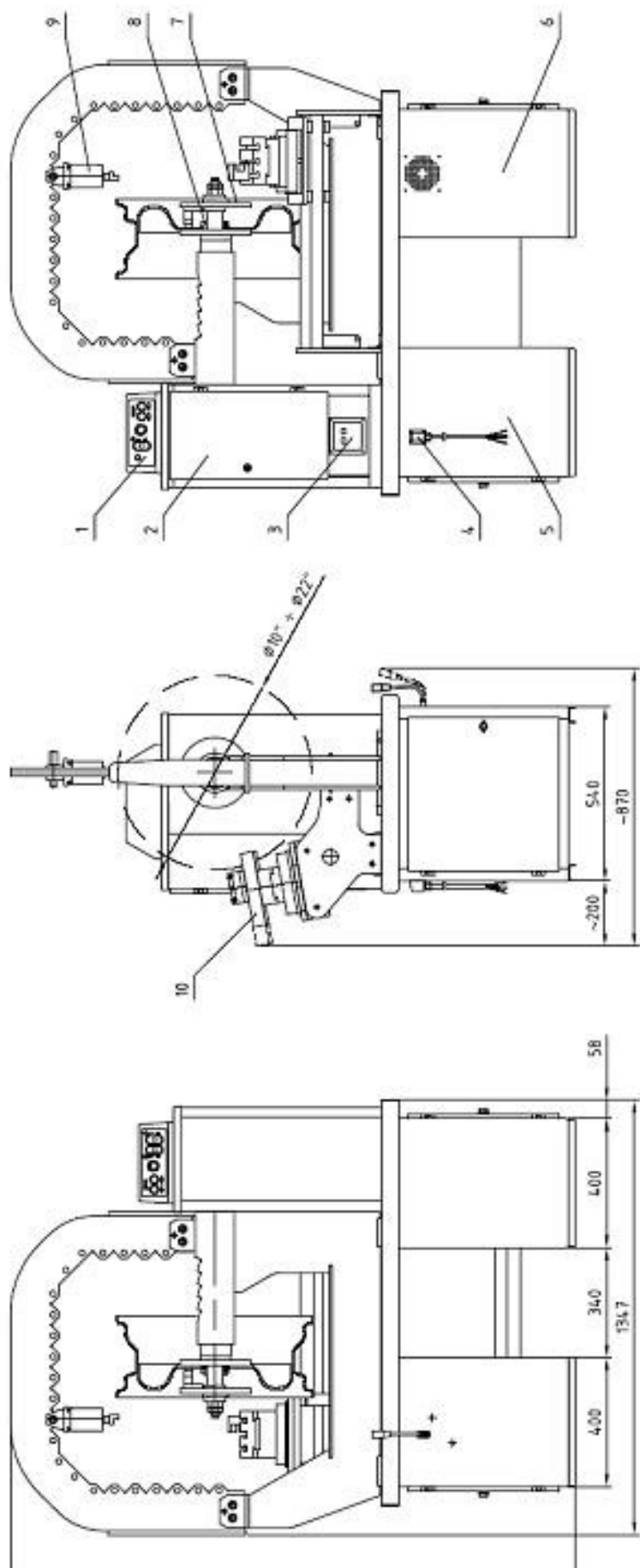

**Fig. 1. Wheel rim straightening machine model PO-22H**

- 1. Control panel
- 2. Electrical box
- 3. Main switch
- 4. Cable connector
- 5. Tools box
- 6. Hydraulic pump box
- 7. Mounting adapter
- 8. Centring ring
- 9. Straightening hydraulic piston
- 10. Lathe adapter

### **10.3 ELECTRICAL SYSTEM**

The machine is adapted to alternating current of 3 x 400 V / 50 Hz.

It is supplied with four-wire power supply cable; the green-yellow wire is a protective conductor while the other three wires are the phase conductors.

The main power switch is located on the control box – figure 1.

The machine is supplied with two control panels. The description of particular parts of each panel is presented in the figure 2. The electrical system scheme is presented in the figure 6.

### **10.4 HYDRAULIC SYSTEM**

Straightening and mounting operations on the machine are carried out by means of the hydraulic servo-motors. The use of the hydraulic pump provides the pressure of 200 bar – the working pressure at the overflow valve is set at 160 bar. The monoblock two-chamber hydraulic divider enables to change the direction of the servo-motor pistons movement. The straightening piston's control chamber is switched by means of the hand lever, while the adapter piston's chamber – by means of the electromagnets (switched on by the control panel).

The capacity of the oil tank on the hydraulic pump is about 8 litres. The oil level is checked on the oil indicator – figure 3.

The hydraulic system's scheme is presented in the figure 7.

---

## **11.0 WHEEL RIM STRAIGHTENING MACHINE OPERATION**

---

The machine is supplied with the hydraulic system to mount wheel rims. Clamping is carried by the hydraulic servo-motor set in the central position by means of a suitable adapter - figure 4.

There are three mechanical pressures supplied:

- a four-bolt mechanical pressure and a five-bolt mechanical pressure with regulated setting of bolts from dimension 98 mm to dimension 140 mm.
- a universal mechanical pressure (three-, four-, and five-bolt with regulated setting of bolts from dimension 140 mm to dimension 210 mm (dimensions 98-210 mm for the three-bolt system).

## 11.1 GENERAL PROTECTION INSTRUCTIONS

Before operation of the wheel rim straightening machine, read attentively the following instructions:

- Some rims require the use non-standard of centring rings or working tools. In order to provide correct operation and safety, non-standard spare parts must be re-supplied by the manufacturer (or the distributor) on the customer's order against payment.
- The machine is used to correct wheel rims. If after the shape correction the rim needs to be balanced, it must be done on the proper machine (balancing machine).
- The machine is not adapted to operations involving washing. The use in humid conditions is not recommended.
- The machine must not be used by unauthorised personnel.
- The machine must be used only according to its purpose.
- Make sure the rims and the standard equipment tools, used during correction, meet the instructions of the manufacturer.
- Before operation, check the indicator of the oil level of the hydraulic pump.
- Make sure the motor is turning in the right direction.
- If the machine is not working properly, turn it off and call for the technical service.
- In case of sudden accidents and/or during the machine's inspection, press the "emergency stop" (ENERGIA STOP) button.
- Do not modify the safety devices.
- Fix all parts of the machine carefully in order to avoid any hazards, and wear protective goggles.
- Proceed slowly during operation with the straightening piston; Rapid use of piston with big force may caused a durable damage of the rim. You must wear the protective goggles during this operation.
- Always check a proper clamping the rim in the adapter.
- Always monitor the normal level of the pressure. If it exceeds, turn the machine off.
- Always control the direction of the motor's movement. Rotation in the wrong direction may damage the motor and the machine.
- Do not overload the machine's hand control lever.

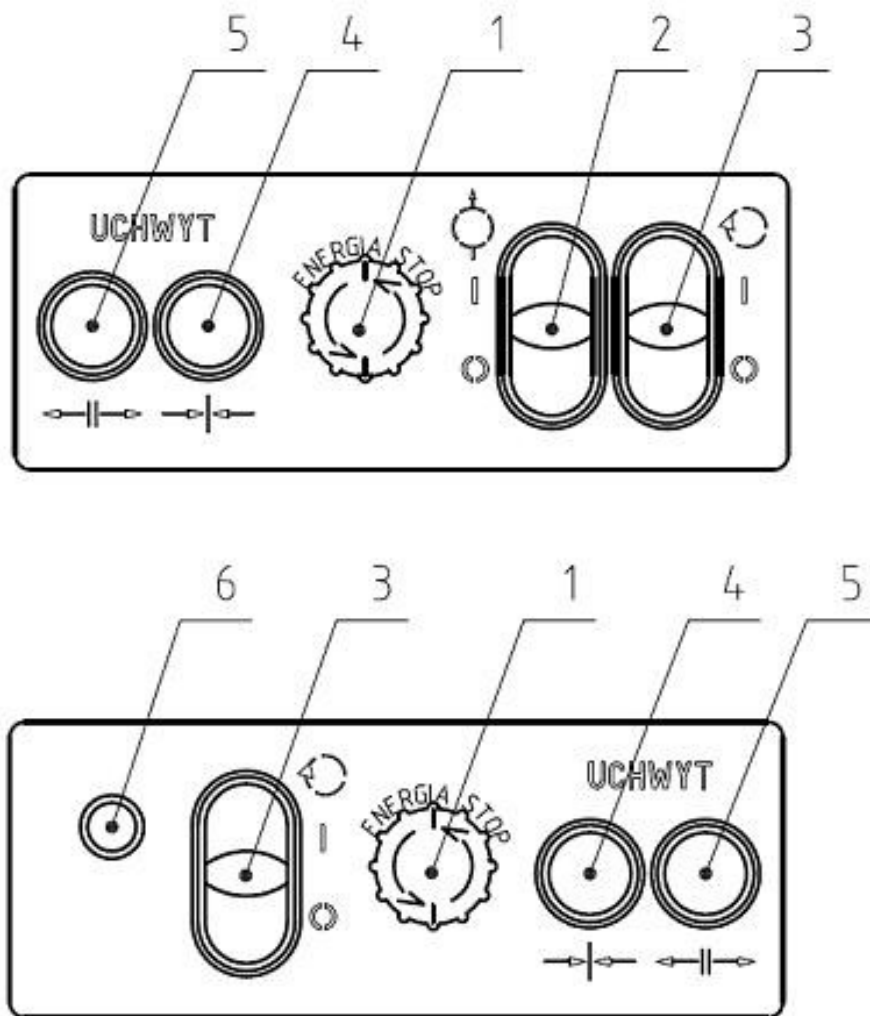

**Fig. 2. CONTROL PANELS**

1. Emergency stop button
2. Hydraulic pump switch
3. Drive motor switch
4. Hydraulic adapter connecting (clamping) button
5. Hydraulic adapter disconnecting (loosening) button
6. Electrical system signal LED diode

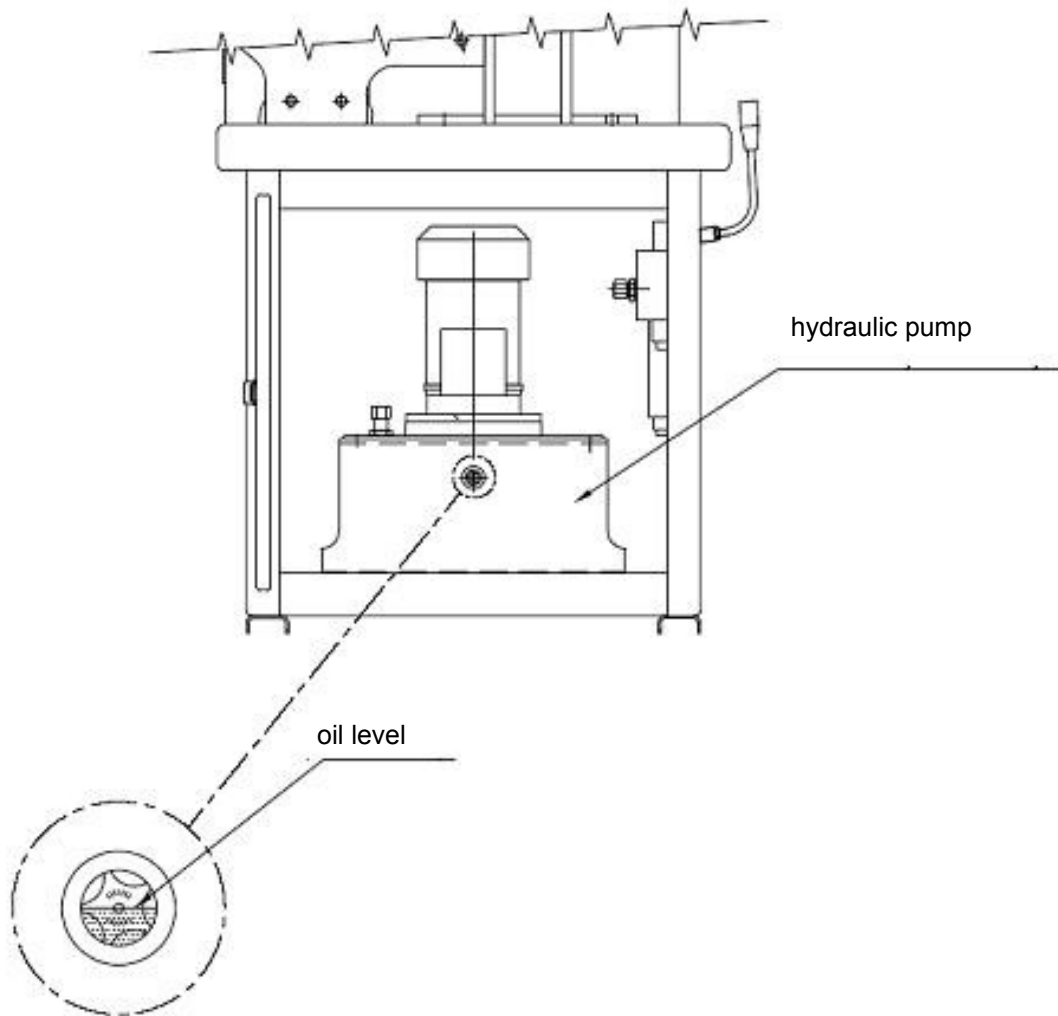

**Fig. 3. Hydraulic pump**

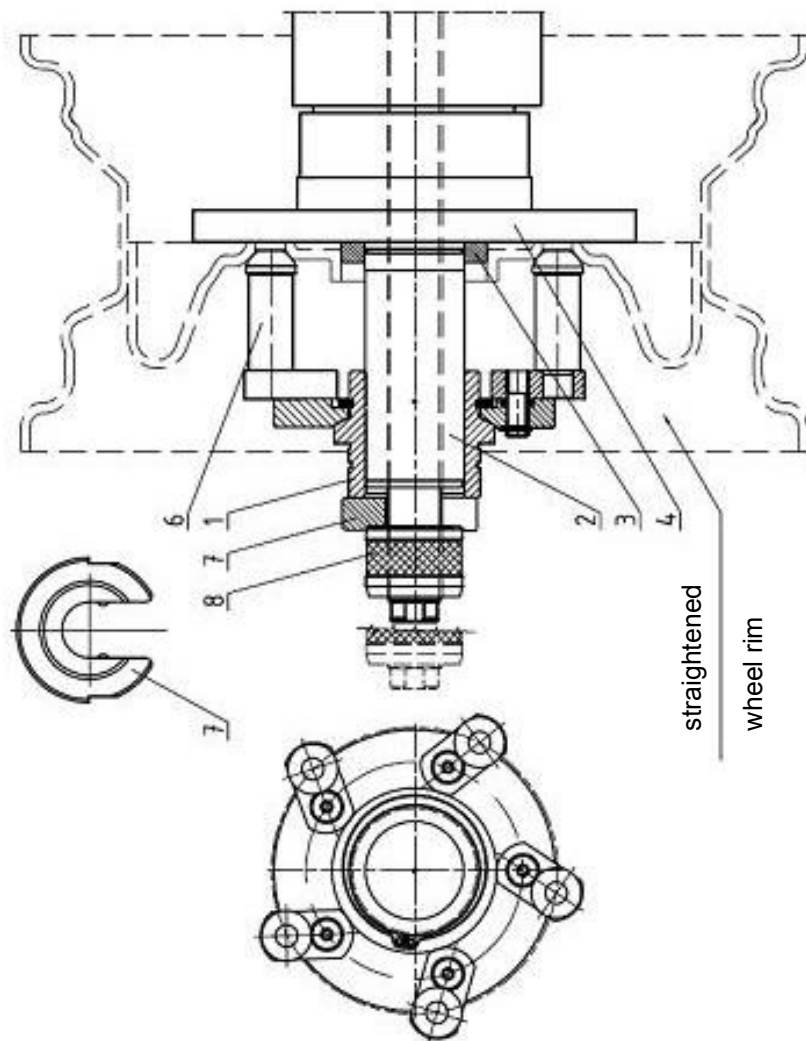

Fig. 4. Mounting a wheel rim on the machine's spindle

## 11.2 MOUNTING AND DEMOUNTING SYSTEM OPERATION (Figure 4)

### Wheel rim mounting:

- Choose the proper mechanical pressure (Fig.4 no.1) for the rim which is going to be straightened.
- On the spindle (Fig.4 no.2), slide the centring ring (Fig.4 no.3) with the outer diameter adapted to the diameter of central hole of rim.

- Slide the rim until it leans on the flanche of adapter (Fig.4 no.4).
- Slide the mechanical pressure (Fig.4 no.1) on the spindle (Fig.4 no.2) until the bolts (Fig.4 no.6) are set in the holes of the screws which fix the wheel to the car's hub.
- Put the washer (Fig.4 no.7) on the spindle (the flat side to mechanical pressure) between the mechanical pressure and the nut of adapter (Fig.4 no.8).
- Turn the nut of adapter (Fig.4 no.8) manually.
- Press and hold the button (Fig.2 no.4) on the control panel until the rim is mounted securely.

### **Wheel rim demounting:**

- Press and hold the button (Fig.2 no.5) on the control panel (Fig.2) until can be possible unscrew the nut (Fig.4 no.8) of adapter.
- Remove the washer (Fig.4 no.7).
- Take off the mechanical pressure (Fig.4 no.1) and then the repaired rim.

### **11.3 SENSOR**

Faults of rim are indicated by the mechanical sensor. The sensor's base is supplied as a magnetic mount (with magnetic short-circuiting switch) which allow to use the sensor at every angle. Positions of the faults can be marked by use a piece of chalk.

### **11.4 CORRECTION**

After finding and marking a desired places of flaws of rim, can begin to correct them. The operator must equipe the straightening piston in working tools, adequate to eliminated fault of rim. Next the operator must find adequate point of support or point of fixing of straightening piston. Choice mentioned points must be adequated to use a proper force of straightening piston, directed on the contrary to force which was caused a fault of rim. Recommended is that all movements of piston must be slow and soft. Overly powerful movements of piston can cause new and other faults or permanent damage of rim.

Recommended is that corrected alloy rims can be heat up in points of correction by the propane-butane burner to temperature 250 – 350 degrees Celsius.

The operator must remember that all repairs of rims must be perform with his special attention and use adequate working tools and with safety meassures.

---

## **12.0 WHEEL RIM SPREADING DEVICE**

---

Additionally, the machine is supplied with the hook device to correct shape of rims which are strongly deformed. The installation instructions for the hook device are presented in the figure 5.

Pressing the lever number 4, the straightening piston number 2 turns it around and moves the hook number 5 along.





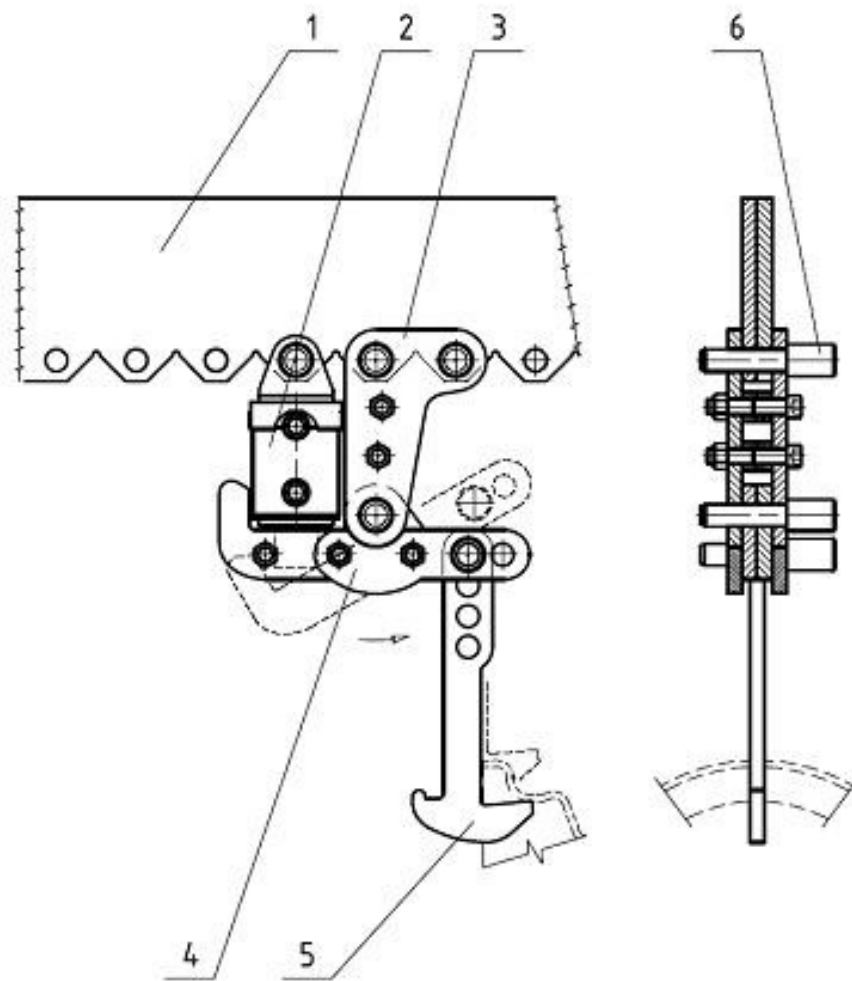

1. Machine's frame
2. Straightening piston
3. Support
4. Lever
5. Spreading hook
6. Bolt

**Fig. 5. Hook device**

### **13.0 Accessories – standard equipment**

No.	Name		Amount
1	Preliminary straightening lever		1
2	S-shaped tool		1
3	Angle tool		1
4	Hammer tool		1
5	Locking washer		1
6	Magnetic mount		1
7	Scriber		1
8	Rod	l=63 mm	1
9	Rod	l=188 mm	1
10	Rod	l=88 mm	1
11	Rod	l=113 mm	1
12	Middle rod	l=96 mm	1
13	Middle rod	l=174 mm	1
14	Centring ring	D=64 mm	1
15	Centring ring	D=63.3 mm	1
16	Centring ring	D=60 mm	1
17	Centring ring	D=59.5 mm	1
18	Centring ring	D=72 mm	1
19	Centring ring	D=66.5 mm	1
20	Centring ring	D=66 mm	1
21	Centring ring	D=57 mm	1
22	Centring ring	D=56.5 mm	1
23	Centring ring	D=54 mm	1
24	Centring ring	D=65 mm	1
25	Centring ring	D=58 mm	1
26	Centring ring	D=59 mm	1
27	4-bolt mechanical pressure	D=140 mm	1
28	5-bolt mechanical pressure	D=140 mm	1
29	Universal mechanical pressure	D=205 mm	1
30	Wheel rim spreading device		1

## **14.0 HEALTH AND SAFETY REGULATIONS during operation of the straightening machine**

### **General remarks**

1. You can operate the straightening machine on your own only if:

- you have completed the right professional training;
- you have completed the training in general and fire regulations, as well as the job position training;
- you are in a good health condition, confirmed with the medical certificate;
- you are over 18 years old;
- you have the permission of your direct supervisor (foreman) to operate the straightening machine.

2. You must not start work, if you have any doubts about its safety.

3. You must ask your direct supervisor for comprehensive instructions to solve any difficulties or clear any doubts.

3. Operation of the straightening machine can be carried out only by a person who is well-rested, sober, appropriately dressed up (the work clothing must be tight, without any loose trimmings).

### **Basic operations before the straightening machine operation**

An operator of the straightening machine should:

- read the detailed manual instruction;
- listen to the commands and instructions of the professional supervisor concerning safe and correct task fulfilment;
- consider how to work safely to fulfil one's task;
- prepare necessary helpful workshop equipment, tools, personal protectors (if necessary);
- prepare the work place to fulfil the given tasks;
- report all the faults or hazards immediately to the supervisor in order to remove them quickly.

### **Other operations before the straightening machine operation**

#### **Substantial operations during a wheel rim straightening:**

- mount the wheel rim;
- in case of power failure, turn off the straightening machine immediately;
- focus only on the substantial (safe) operations while using the straightening machine;
- do all your tasks accurately, according to the current manufacturing process;
- do only the tasks ordered by the direct supervisor;
- report all the work accidents immediately to the direct supervisor;
- in case of a work accident, leave your work place in the same condition in which the accident happened, until the emergency team arrives;
- in case of any doubts concerning safe task fulfilment, listen to the instructions of your supervisor and observe all his commands.

#### **Basic operations after work:**

- turn off the straightening machine and protect it from undesirable turning on;
- clean your work place carefully;
- clean and put away your personal protectors;
- check if your work place will not be hazardous after your departure.

---

## **15.0 ELECTRICAL SYSTEM SCHEME**

---

1. HYDRAULIC PUMP MOTOR
2. DRIVE MOTOR
3. HYDRAULIC PUMP MOTOR CONTACTOR
4. DRIVE MOTOR CONTACTOR
5. HYDRAULIC PUMP SWITCH
6. DRIVE MOTOR SWITCH
7. ELECTROMAGNETIC COIL DEMOUNTING HYDRAULIC ADAPTER
8. ELECTROMAGNETIC COIL MOUNTING HYDRAULIC ADAPTER
9. HYDRAULIC ADAPTER DEMOUNTING SWITCH
10. HYDRAULIC ADAPTER MOUNTING SWITCH
11. TIME RELAY

12. RELAY CONTROL TIME RELAY
13. FAN
14. RECTIFIER
15. EMERGENCY STOP BUTTON ( ENERZIA STOP)
16. WARNING LIGHT
17. TRANSFORMER 400 V / 24 V
18. MAIN SWITCH

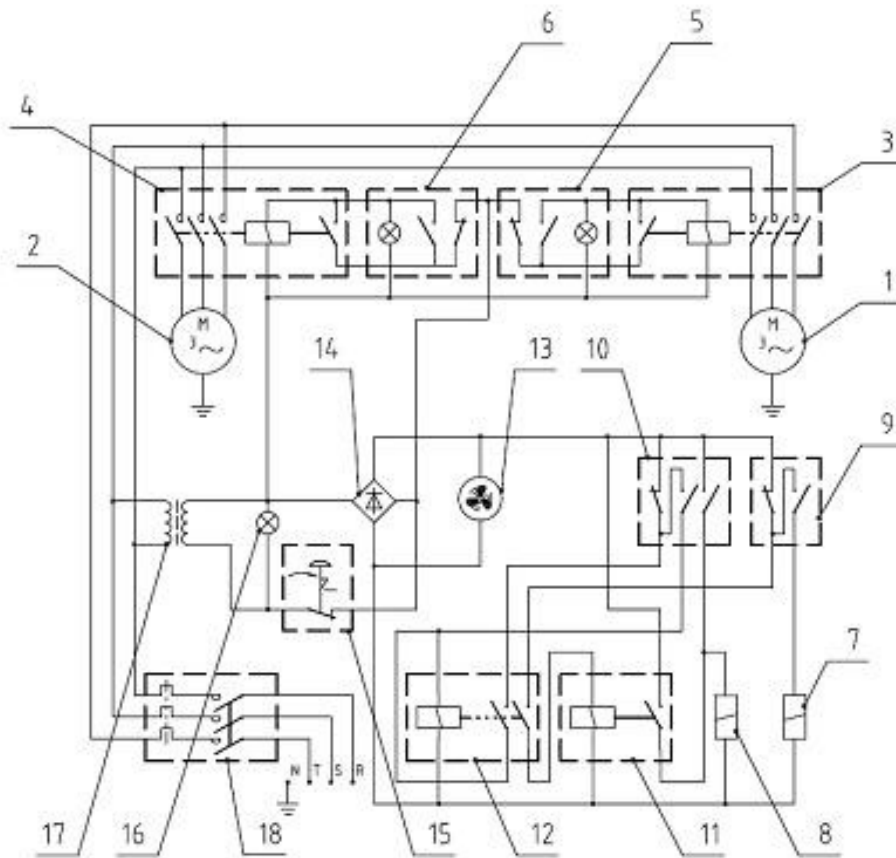

**Fig. 6. Electrical system scheme**

**CAUTION:**

The following control parts used twice in the straightening machine are not shown in the scheme:

- 5 – hydraulic pump switch
- 9 – hydraulic adapter demounting switch
- 10 – hydraulic adapter mounting switch
- 15 – emergency stop (ENERGIA STOP)

## 16.0 HYDRAULIC SYSTEM SCHEME

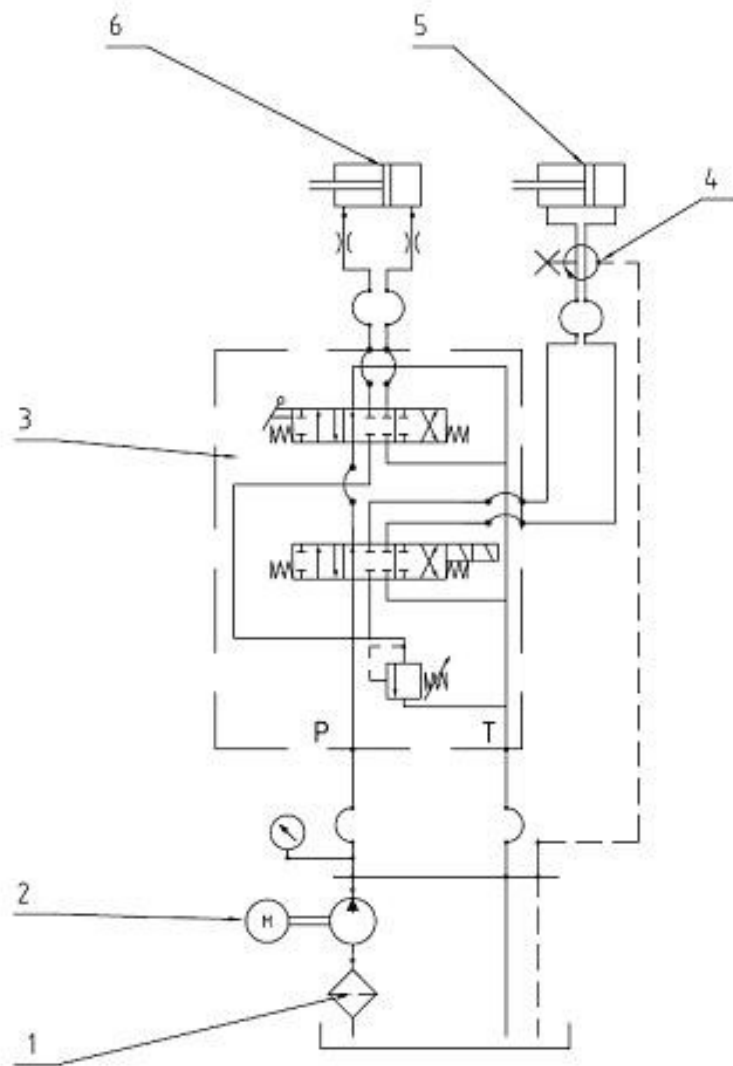

1. Filter
2. Motor – pump assembly
3. Monoblock two-chamber hydraulic divider
4. Rotating joint
5. Adapter servo-motor
6. Straightening piston

**Fig. 7. Hydraulic system scheme of the straightening machine with the monoblock two-chamber hydraulic divider**

## 17. Picture catalogue of spare parts

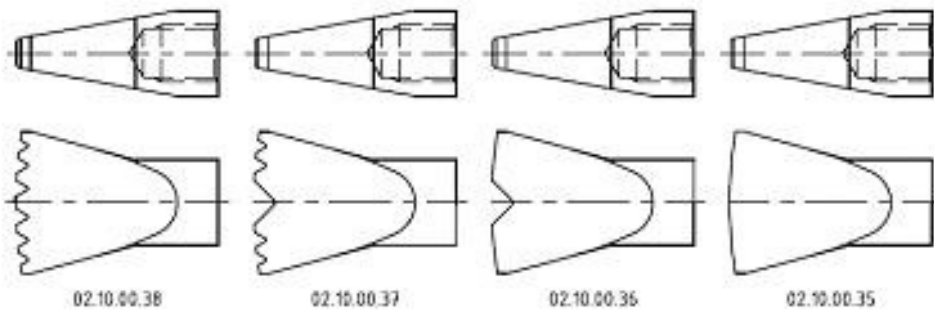

Working tools

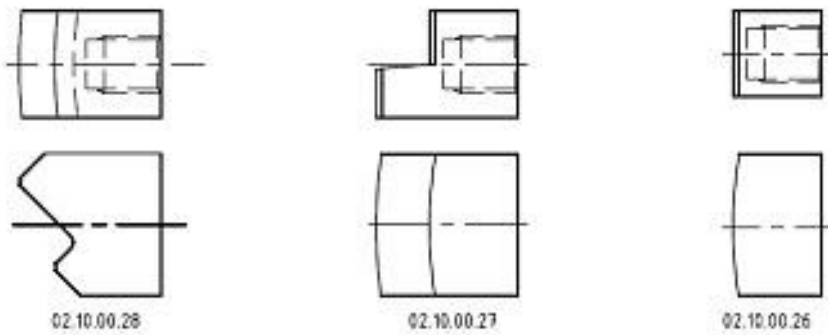

S-shaped working tool

Angle working tool

Hammer working tool

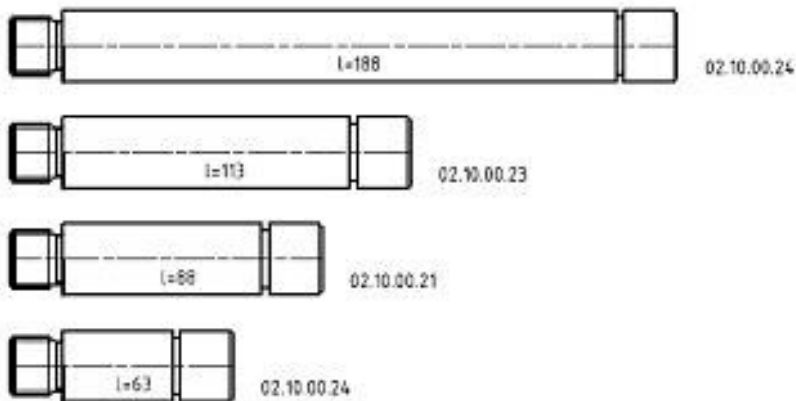

Rods for working tools

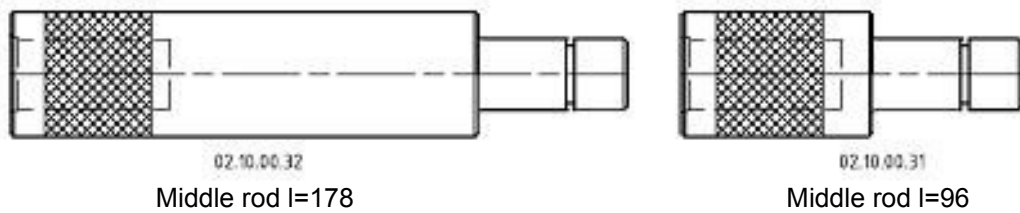

Middle rod l=178

Middle rod l=96



17. Picture catalogue of spare parts

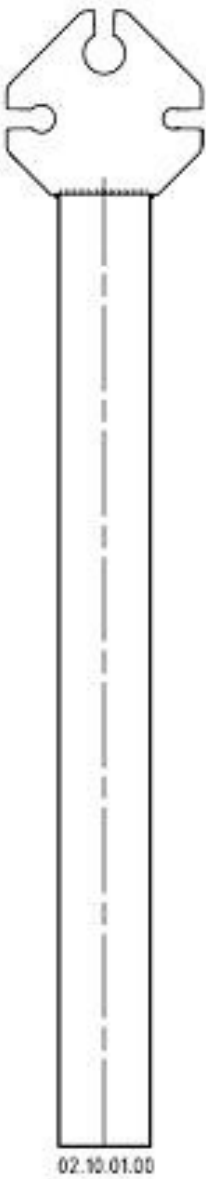

02.10.01.00  
Preliminary straightening lever



02.10.00.08  
Scriber

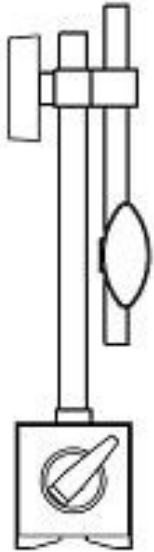

LIMIT measurement support (magnetic mount)

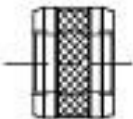

02.25.00.02  
Nut of adapter M27x2



02.25.00.03  
Locking washer

## 17. Picture catalogue of spare parts

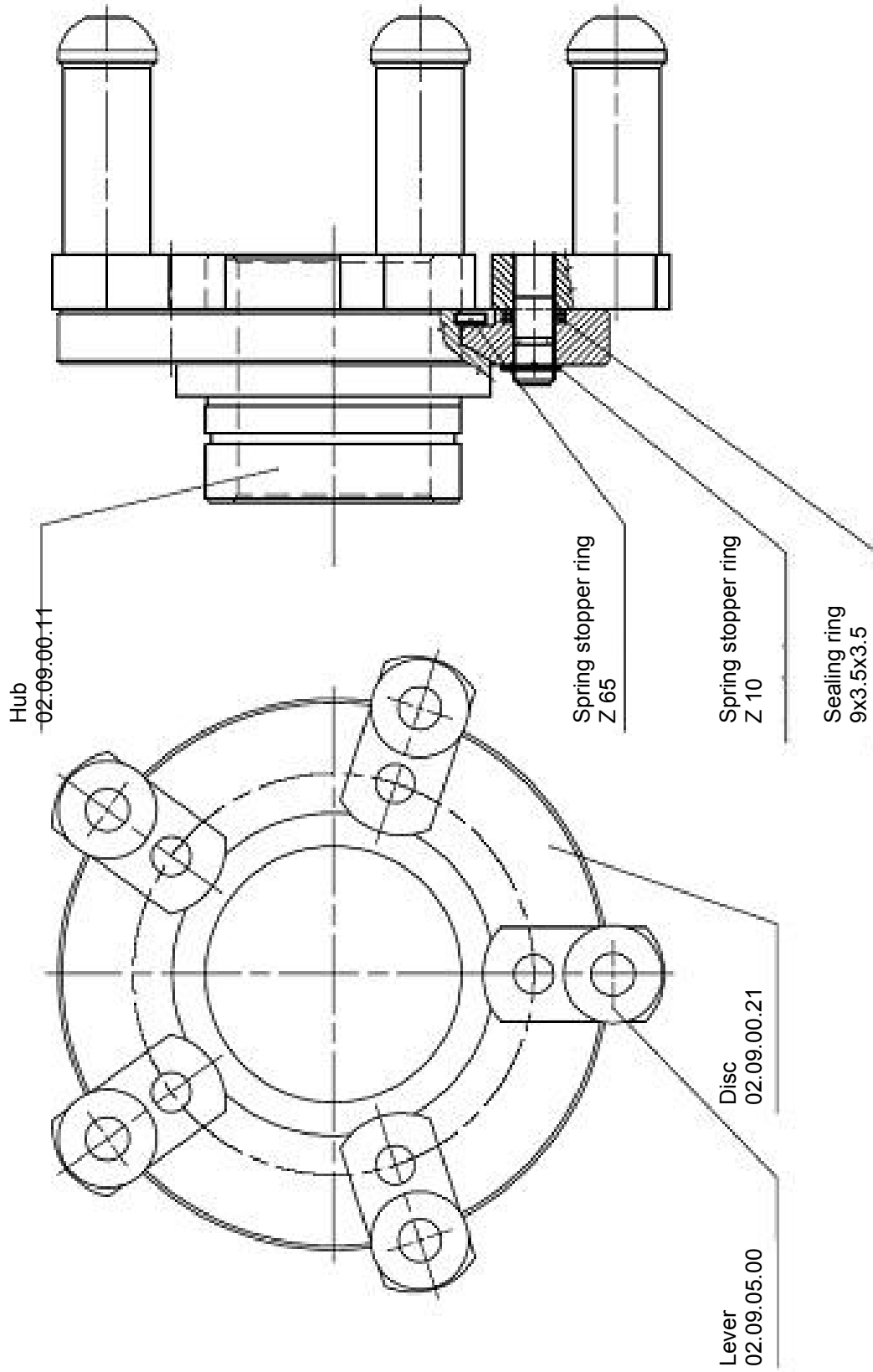

**5-bolt mechanic pressure with regulated setting of bolts from Ø 92 to Ø 140**

## 17. Picture catalogue of spare parts

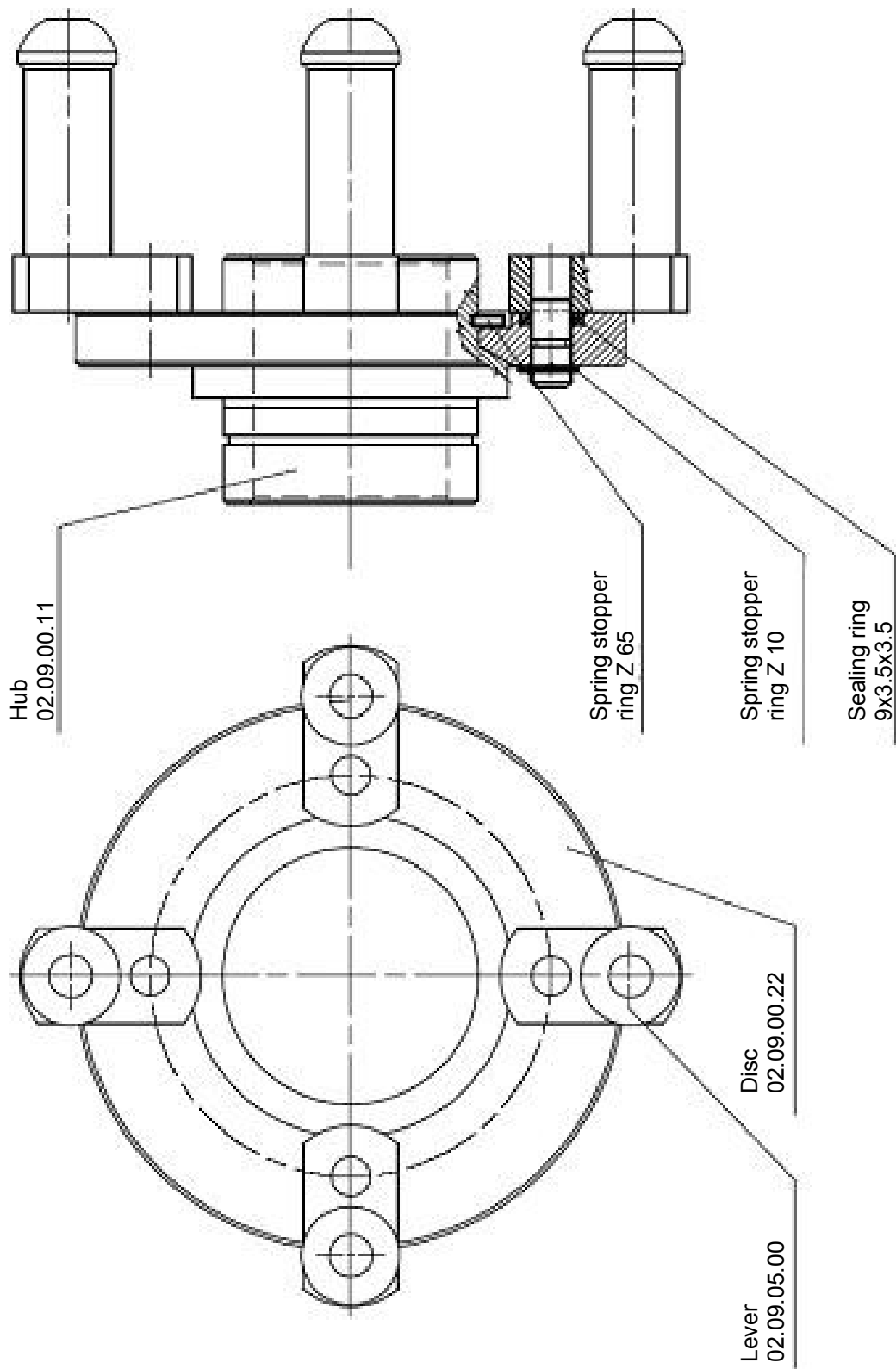

**4-bolt mechanical pressure with regulated  
setting of bolts from Ø 92 to Ø 140**

## 17. Picture catalogue of spare parts

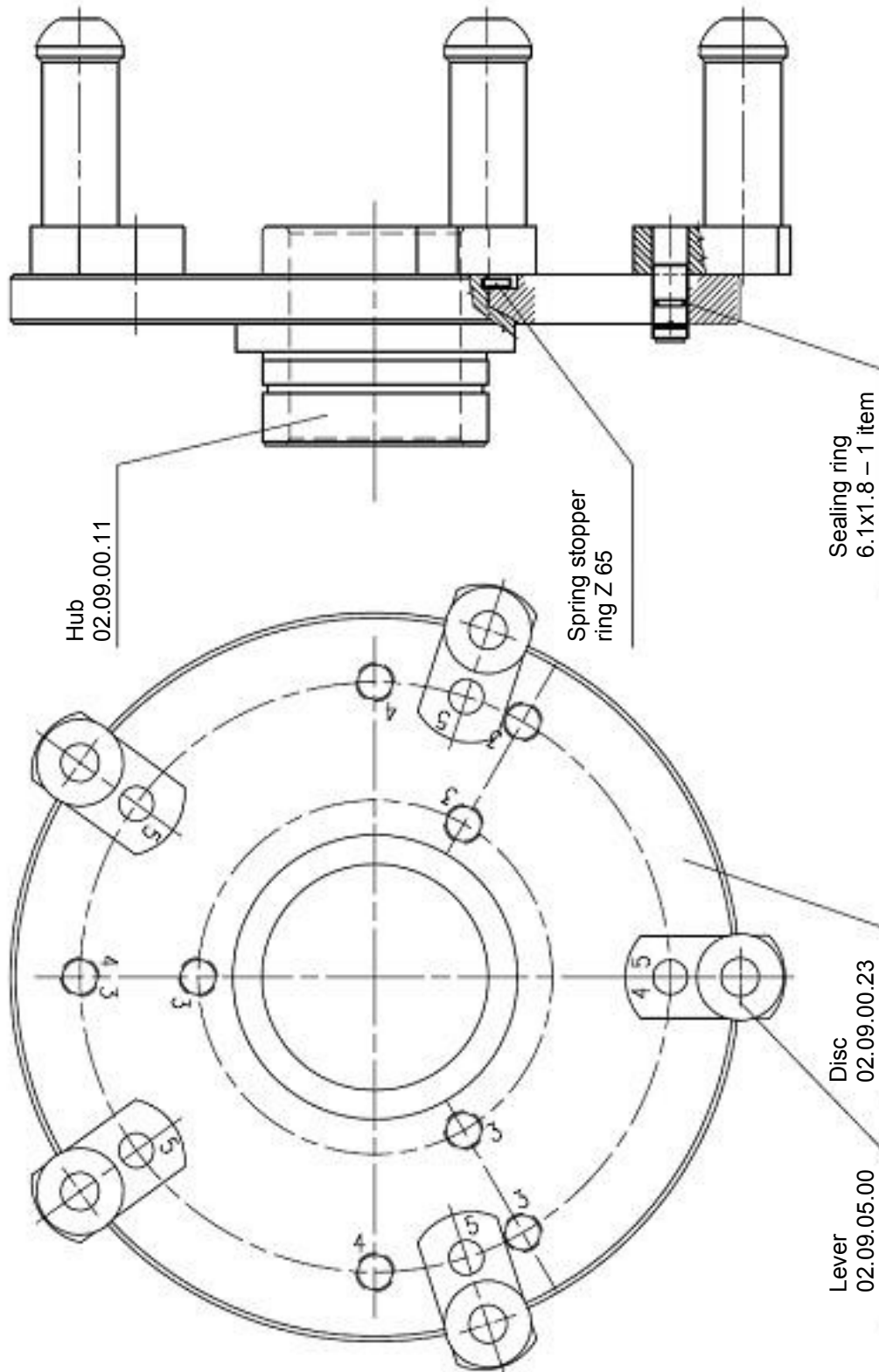

Universal mechanical pressure with regulated setting of bolts from Ø 92 to Ø 210



## CE Conformity Declaration

in accordance with directives : 2006/42/CE, 2006/95/CE, 2004/108/CE

We: **Uni-Trol Co. Ltd.**  
**Ul. Estrady 56**  
**01-932 Warsaw**  
**Poland**

declare, under our exclusive responsibility, that the product

**WHEEL RIM STRAIGHTENING MACHINE**  
Electromechanical and hydraulic device  
**Model PO-22**

serial number.....

concerned by this declaration, complies with all relevant requirements of the Machinery Directive:

- **Directive 2006/42/EC (safety machines),**

applicable in the essential requirements and relevant conformity assessment procedures, as well as on the essential requirements of the following directives:

- **Directive 2006/95/CE ( the low voltage );**

- **Directive 2004/108/CE ( the electromagnetic compatibility ).**

For verification of conformity with the provisions of law were consulted the harmonized standards or other

norms documents :

PN-EN ISO 12100:2012P

Safety of machinery. Basic concepts, general principles for design. Part 1: Basic terminology, methodology

PN-EN 61000-6-3:2008P

Electromagnetic compatibility (EMC). Part 6-3: Generic standards. Emission standard for residential, commercial and light industrial (org.)

PN-EN 61000-6-4:2008P

Electromagnetic compatibility (EMC). Part 6-4: Generic standards. Emission standard for industrial environments (org.)

PN-EN ISO 13857:2010P

Safety of machinery. Safety distances to prevent reaching the upper limbs and lower the danger zones (org.)

PN-EN 349+A1:2010P

Safety of machinery. Minimum gaps to avoid crushing of parts of human body (org.)

PN-EN 60204-1:2010P

Safety of machinery. Electrical equipment of machines. Part 1: General requirements (org.)

PN-EN 61293:2000P

Marking of electrical equipment with ratings related to electrical supply - Safety requirements;

PN-EN ISO 4413:2011E

Hydraulic drives and controls - General rules and safety requirements for systems and their components

PN-EN ISO 11201:2012P

Acoustics - Noise emitted by machinery and equipment - Determination of emission sound pressure levels at a work station and at other specified positions in an essentially free field over a reflecting plane with negligible environmental corrections

PN-EN ISO 11202:2012P

Acoustics - Noise emitted by machinery and equipment - Determination of emission sound pressure levels at a work station and at other specified positions applying approximate environmental corrections

PN-EN ISO 4871:2012P

Acoustics - Declaration and verification of noise emission values of machinery and equipment

PN-EN 50419:2008P

Marking of electrical and electronic equipment in accordance with Article 11 (2) of Directive 2002/96/CE (WEEE)

The technical documentation mentioned product, as specified in Annex VII A, point 1 of the Machinery Directive, is located in the headquarters Uni-trol Ltd. (address as above) and will be made available to the competent national authorities for at least ten years from the date of the last piece.

The person responsible for the preparation of the technical documentation of the product and introducing changes in it, is MSc. Gregory Tworek - Member of the Board.

This EC Declaration of Conformity will be kept by the manufacturer of the product for 10 years from the date of produce the last unit and will available for market supervisory authorities for verification.

MSc. Gregory Tworek - Member of the Board.