

CE

Wheel Balancing Machine

TROLL 2351L

OPERATING MANUAL



Operating manual

Wheel balancing machine for passenger cars and motorcycles TROLL 2351L

Serial number

Production year

MANUFACTURER

Uni-Trol Sp. z o.o.
ul. Estrady 56, 01-932 Warszawa
tel./fax +4822 834 90 13-14, +4822 817 94 22
NIP 527-020-52-46

AUTHORISED SERVICE

Uni-Trol Sp. z o.o. – SERVICE
ul. Estrady 56, 01-932 Warszawa
tel./fax +4822 834 90 13-14, +4822 817 94 22
NIP 527-020-52-46

Table Of Content

Packing, transportation and storage	6
1. Introduction.....	7
1.1 The manual	7
1.2 Preliminary work with the balancing machine.....	7
1.3 Machine's identification data	8
2. Description of the balancing machine.....	9
2.1 Machine equipment	10
2.2 Keyboard description	10
2.3 Technical specification	12
3. Safety	13
3.1 General precautions.....	13
4. Maintenance and scrapping of balancing machine	15
4.1 Maintenance	15
4.1.1 Periodical maintenance	15
4.2 Machine scrapping	15
4.2.1 Fire protection.....	16
4.2.2 Accident prevention	16
4.2.3 Safety designing provided in the balancing machine	16
4.2.4 Noise evaluation	16
5. Installation of the balancing machine	17
5.1 Installation requirements	17
5.1.1 Power supply source requirements	17
5.2 Place of installation	17
5.2.1 Required working area.....	17
5.3 Mounting car wheels' holder	18
5.3.1 Description of the holder's elements	19
5.3.2 The clamp nut	19
5.4 Mounting the spike holder.....	19
5.5 Mounting motorcycle wheels' holder	21
5.6 Mounting the hood	22
5.7 Installing and connecting LCD display	22
5.8 Fixing wheels on balancing machine's holders	23
5.8.1 Car wheel	23
5.8.2 Car wheel in spike holder	26
5.8.3 Motorcycle wheels.....	27
6. Machine programs.....	28

6.1	Activating the balancing machine	28
6.2	Machine's main menu	28
6.3	Machine settings.....	29
6.3.1	Sound	29
6.3.2	Balancing	30
6.3.3	USG	30
6.3.4	Clock.....	31
6.3.5	Printing	31
6.3.6	Miscellaneous	31
6.4	Balancing program	31
6.4.1	Inputting parameter values from keyboard.....	33
6.4.2	Selecting weight placement mode	33
6.4.3	Changing of threshold.....	34
6.4.4	Changing screen mode.....	34
6.4.5	Selecting machine's measurement mode	34
6.4.6	"Hidden weight" program.....	35
6.4.7	Initiating the measurement	37
6.4.8	Automatic wheel positioning	39
6.5	Optimisation	39
6.5.1	Optimisation special cases	42
6.6	Calibration	42
6.6.1	Calibration mode selection	43
6.6.2	Calibration using the device	43
6.6.3	Calibration using a wheel	43
6.6.4	Balancing a wheel before calibrating with it	44
7.	Adjuster	45
7.1	Working with adjuster with weight placement mode selected	46
7.1.1	<i>Adjuster</i> mode.....	46
7.1.2	<i>EASY</i> mode	47
7.2	Automatic weight placement selection.....	49
7.2.1	<i>EASY</i> mode and automatic weight placement selection	50
8.	User memory.....	51
8.1	Memory reading	51
8.2	Saving to memory	52
8.3	Editing the memory bank name.....	52
9.	Diagnostics and fault detection	53

Packing, transportation and storage



ATTENTION: All operations concerning packing, lifting, moving, transporting and unpacking must be carried out by qualified personnel only.

Packing

The balancing machine is sent as a complete piece of equipment (quick change holder, balancing machine, protective hood, operating manual). The balancing machine can be packed in a few different ways:

- pallet + stretch foil + carton box
- pallet + stretch foil
- pallet + carton box

Transport

The package can be lifted or displaced by fork-lift or pallet trucks. Once the cargo arrives at its destination, it is recommended to check if its contents have not been damaged during transportation. It is also recommended to check the conformity of the delivery with its bill of landing. In case of non-conformity or transportation damages it is necessary to inform without delay the responsible person or carrier about it. Moreover, the loading should be done with extreme precautions and consideration.



Storage

The machine should be stored in a dry room free of dust.

1. Introduction



WARNING: This manual is intended for personnel licensed to service the balancing machine (operator) and those who carry out current maintenance. Before starting any operations concerning the balancing machine or the package, one should carefully study the manual. It contains important information concerning personal security of the operators and maintenance personnel as well as balancing machine's operation.

1.1 The manual

For proper usage of this manual, the following should be applied:

- The manual must be kept in the proximity of the machine in a place of easy access.
- The manual must be kept in a dry place.
- The manual must be used properly with care not to damage it.
- It is forbidden for operators who have not studied this manual to work with a balancing machine.

This manual is an integral part of the balancing machine and should always accompany the machine even if it is going to be sold.



ATTENTION: It is strongly advised to read carefully and repeatedly chapter 3 in which very important information and warnings concerning safety are contained.



WARNING: Illustrations contained in this manual present typical machine parts. It is possible for manufactured parts to slightly differ from those illustrated in this manual.

1.2 Preliminary work with the balancing machine



ATTENTION: Lifting, transportation, unpacking, assembly, installation, putting in motion, preliminary adjustment and testing, maintenance repairs, technical inspections, do not require the presence of service personnel but must be carried out with extreme precaution.

The manufacturer does not bear any responsibility for personnel injuries or vehicle and other object damages if any of the above mentioned operations will be performed not according to the service manual or the balancing machine was used in an improper way.

In the manual only the aspects of the servicing and security which can help operators and servicing personnel in a better understanding of the construction and working of the balancing machine and to allow them to use it the best way possible were enumerated.

2. Description of the balancing machine

TROLL 2351L balancing machines are designed for balancing of car and motorcycle¹ wheels in a single measurement cycle. Original construction solutions assure safe, simple and comfortable operating of the machine as well as reliability and fast wheel balancing.

TROLL 2351L balancing machine is equipped with:

- Quick mounting holder,
- Hood,
- LCD display,
- Sound speaker,
- Automatic calibration program,
- “Hidden weight” program,
- Optimisation program,
- Imbalance recalculation program,
- ALU programs for working with aluminium rims,
- User memory bank.

The balancing machine has following attributes:

- modern measurement system with a computer system for data processing to ensure fast and complete measurement with great accuracy,
- the possibility to choose a program for wheel handling (also for light aluminium rims) with every type of balancing weights – hammered or adhesive,
- the possibility of regulating balancing accuracy, according to the wheel's mass and state,
- easy programming and measurement with an ergonomic keyboard design,
- versatility of special holders enabling attachment of almost all wheel types,
- automatic calibration system that allows the machine to regulate the measurement system on its own if operator assumes incorrect imbalance indications of the machine,
- ability to adjust user interface and machine mode according to operator's own preferences.

1 Motorcycle holder required.

2.1 Machine equipment



Fig. 2.1 Balancing machine – elements description

No	Name
1	Hood
2	Arm of the hood
3	Collar of hood's axis
4	LCD display
5	Video signal
6	Display's support
7	Display's angle regulator
8	Power cable
9	Holders for additional elements
10	Machine's main switch
11	Keyboard
12	Adjuster with laser point
13	Laser line
14	Ultrasonic sensor

Table 2.1 – description of balancing machine's elements from fig. 2.1

2.2 Keyboard description

Figure 2.2 shows the balancing machine's keyboard (11 in fig. 2.1). All functions of each button have been described in table 2.2.

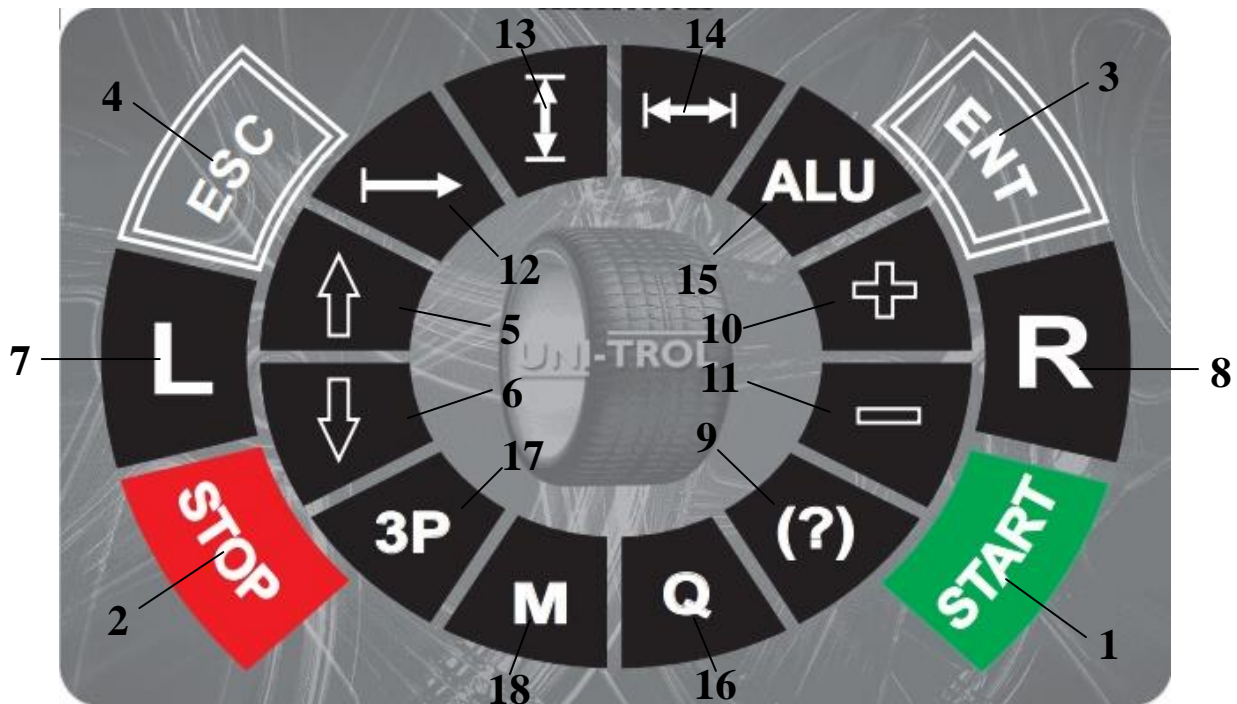

Fig. 2.2 The balancing machine's keyboard

No	Name	Function
1	Start	Starting of measurement cycle
2	Stop	Stopping a measurement cycle / clearing last measurement
3	Enter	Entering a program / submenu
4	Escape	Exiting a program / submenu
5	Up arrow	Move cursor up
6	Down arrow	Move cursor down
7	Left	Turn the wheel to left imbalance point / move cursor left
8	Right	Turn the wheel to right imbalance point / move cursor right
9	Magic button	Recalculate current imbalance of the wheel
10	Plus	Increase / change chosen parameter
11	Minus	Decrease / change chosen parameter
12	Distance	Shortcut - moving cursor to distance parameter
13	Diameter	Shortcut - moving cursor to diameter parameter
14	Width	Shortcut - moving cursor to width parameter
15	ALU	Shortcut - moving cursor to weight placement
16	Q	Shortcut - moving cursor to threshold changing
17	3P	Activate "hidden weight" program
18	Memory	User memory

Table 2.2 Description of buttons' functions

2.3 Technical specification

Wheel diameter	10"-26"
Wheel width	2"-20"
Imbalance indication accuracy	1g
Imbalance location signal accuracy	3°
Measurement time	7s
Wheel weight	Up to 60kg
Drive motor rating	80W
Spindle rotation speed during measurement	160 rpm
Overall dimensions	
No hood, no display, with wheel holder	1000 x 580 x 900 mm
With hood and display, hood closed	1170 x 850 x 1260 mm
With hood and display, hood opened	1170 x 1000 x 1450 mm
Total machine weight	approx. 85 kg
Power supply	230V/50Hz
Average level of acoustic pressure L_{AV}	65 dBA

3. Safety



WARNING: This chapter should be read carefully because it contains important information for operators and other persons concerning hazards of using the balancing machine in an inappropriate way.

Below are explanations concerning hazards and risks which can occur during balancing machine operating and maintenance. General and detailed precautions are given for avoiding potential hazards.



Warning: The TROLL 2351L balancing machine was designed for the balancing of car and motorcycle wheels in one measurement cycle. Any work with the balancing machine should be preceded by comprehensive reading and understanding of this manual. Any other type of usage of this balancing machine is not allowed. In particular, the balancing machine is not intended for balancing other elements or balancing truck wheels.



ATTENTION: The producer and the dealer do not bear any responsibility for personnel injuries or vehicle and other objects' damages in case of improper or unauthorized use of the balancing machine.

Any operation of the balancing machine is not allowed without prior closing of the hood. Not satisfying the above mentioned recommendations can result in serious human injuries and irreparable balancing machine's damages and wheel damages.

3.1 General precautions

It is required that the operator and the maintenance technician adapt safety rules obligatory in the country of installation. Moreover, the operator and the maintenance staff should read all the information regarding safety placed on the machine and all the information included in this manual.

Risk of electric shock – hazard of electric shock can occur in those balancing machine areas, where electric cables are placed. Use of water sprayers, vapour sprayers (high pressure washing units), dissolvers and painting equipment is not allowed in vicinity of the balancing machine and in particular they should not be in contact with the control unit.

Impact risk – during operation of the machine here is a risk of some parts of the balancing machine hitting the operator. With the protective screen open, personnel must preserve all precautions to avoid hitting against machine parts.

Risk of wheel easing – before balancing starts, one should check if the wheel is properly and firmly fixed in its holder.



ATTENTION: It is forbidden to unscrew the wheel during machine work!
It is forbidden to leave the machine unattended during work!
It is forbidden to use wheels exceeding the maximum wheel weight!
It is forbidden to initiate a measurement with an incorrectly mounted wheel!

Skid risk – this hazard can be caused by floor contamination with grease in the proximity of the balancing machine. The area under the balancing machine, the holders and the area near them must be kept clean at all times. All the oil spots should be removed instantly.

Hazard caused by poor illumination – the operator and the maintenance technician must have the possibility to check if all areas of the balancing machine are properly and uniformly illuminated according to the regulations applied in the installation place.

Risk of balancing machine defect during work – to produce a reliable and safe balancing machine, the manufacturer applied suitable materials and manufacturing techniques that are necessary for this type of equipment. Nevertheless the balancing machine should be operated according to the producer's recommendations. Technical service (after warranty period) and other maintenance works described in chapter 4.1 "Maintenance" should be carried out with specified periodicity.



ATTENTION: All operations of the balancing machine contrary to its function can cause danger, serious damage or accidents to anybody near the machine. It is crucial to scrupulously observe all recommendations contained in this manual concerning maintenance and safety.

Risk involving machine's moving parts – During any kind of operations all limbs should be kept as far from moving parts as possible at all times. Necklaces, bracelets and loose clothes as well as long hair may cause potential danger to the operator. It is mandatory to take any jewellery off, wear clothes fit close to body and use headgear. The operator should use appropriate shoes to prevent any lower limb injuries.

Risk caused by laser radiation – The laser point adjuster system is equipped with two low-power laser diodes. The machine is designed in such a way that both laser diodes are never pointing upwards. The main principle regarding usage of the laser adjuster is avoiding eye and skin contact with radiation and – most importantly – **not looking straight into the lasers**.

4. Maintenance and scrapping of balancing machine

4.1 Maintenance

Maintenance should be conducted by experienced personnel with knowledge concerning the principles of balancing machine's operation. During the maintenance process one should preserve all precautions in order to avoid any accidental start of the balancing machine. The master switch should be pushed out and its light should be off. One should also adhere to all instructions given in chapter 3.

4.1.1 Periodical maintenance

In order to keep the balancing machine in a good operational state one should observe the below mentioned indications:

- Clean your balancing machine at least once a month without using any chemical washing agents or high pressure spray guns.
- Check the operational state of all equipment periodically.
- Lubricate all holders periodically and keep them clean.
- Check the state of all cords once a year.



ATTENTION: Disregard of these recommendations will dismiss the manufacturer from any responsibility included in warranty.



WARNING: Always remove all dirt from the area near the balancing machine.

4.2 Machine scrapping



ATTENTION: During machine scrapping one should preserve all precautions described in chapter 3, also applied during assembly.

As well as assembly, disassembly has to be executed by trained personnel only. All metal parts should be utilized as metal scrap. In all cases of machine scrapping, the utilization of all materials has to be conducted according to the rules applied in the country of installation. One should also notice that for tax purposes, effective machine scrapping should be documented in reports and forms according to the rules applied in the installation country.

4.2.1 Fire protection

The machine does not constitute fire hazard. Nevertheless, room in which the balancing machine is installed, has to fulfil requirements of fire protection regulations applied in the country of installation.

Always keep one or more portable fire extinguishers within the operator's reach (operator zone), in order to prevent any fire hazard.

4.2.2 Accident prevention

During lifting/lowering, shifting, installing, assembling and disassembling of the balancing machine, one should preserve all precautions provided in regulations concerning accident prevention applied in the installation country. Moreover, all regulations concerning fork-lift trucks have to be preserved.

4.2.3 Safety designing provided in the balancing machine

The machine has been equipped with a hood, which protects the operator with revolving parts of the balancer. The machine has been designed in such manner as not to initiate a measurement by accident or start one with the hood opened.

Each measurement initiation has to be preceded with pressing the *START* button, which starts only a single measurement (assured by software). Due to many safety design constructs, it is impossible for the machine to initiate any kind of measurement sequence on its own.

If any other incidental situations not mentioned in this operating manual occur, the operator is to immediately stop working with the machine, call authorized service and describe the problem.

4.2.4 Noise evaluation

Noise emission approximations were conducted in ordinary surroundings for a wheel balancing machine using environmental correction, defined and simplified by norm PN-EN ISO 11202. Measurements were made using a 20" wheel, weight approximately 35kg and in correct working conditions, i.e. nominal power supply conditions.

Measurements using a calibrated microphone were performed during a period from start of measurement and reaching maximal rotation speed to turning the drive motor off and stopping the wheel completely. For evaluation purposes an average from a couple of maximised measurements has been taken.

Average level of acoustic pressure $L_{av} = 65$ dBA .

5. Installation of the balancing machine



WARNING: These operations can be executed by persons who were earlier trained in servicing equipment described in this manual. To avoid possible balancing machine damage or causing human injuries, it is necessary to preserve mentioned instructions. One must make sure nobody is within the working area of the machine.

5.1 Installation requirements

The balancing machine has to be installed at a safe distance from walls, columns or any equipment. The room must be equipped with an electric power source. The balancing machine can be positioned on any surface, provided it is hard and perfectly horizontal. All parts must be uniformly illuminated, for the light intensity assures safe completion of all regulations and maintenance works specified in this manual. The presence of shaded places, light reflections or dazzling light is unacceptable. One must avoid any situations leading to eye fatigue. Illumination must be installed according to the regulations obligatory at the installation place (it is the responsibility of the light installation contractor).

Before starting the installation process, it is recommended to unpack all parts and check for any type of damage. All matters concerning displacing and lifting were discussed in chapter “Packing, transportation, storage”.



ATTENTION: THE MACHINE MUST NOT BE PERMANENTLY SCREWED TO ANY SURFACE! HOLES IN THE BOTTOM PART OF THE MACHINE ARE FOR TRANSPORTING PURPOSES ONLY!

5.1.1 Power supply source requirements

Balancing machine is powered using a single phase alternating current 230V 50Hz. It should be connected to a power socket using an appropriate plug and secured with a 30mA residual-current fuse. Additionally the machine is protected from overcurrent using a 2A fuse.

5.2 Place of installation

The balancing machine should be installed in a locked, dry and heated (during autumn/winter season) room. Humidity should be between 30% and 95% with no vapour condensation. Temperature should be kept between 0–55°C. The surface on which the balancing machine will be standing should be hard and horizontal. The machine should be placed on 3 rubber backings provided with the equipment. They should be placed under 3 legs welded to the balancing machine's base.

5.2.1 Required working area

Balancing machine's measurements designate its working area. Persons not qualified or permitted

to operate it are not allowed in this area. Maximal requirements concerning the working area are 2870x3000 mm given minimal distance to walls, what has been presented in fig. 5.1. Numbers 1 and 2 designate operator's working setting.

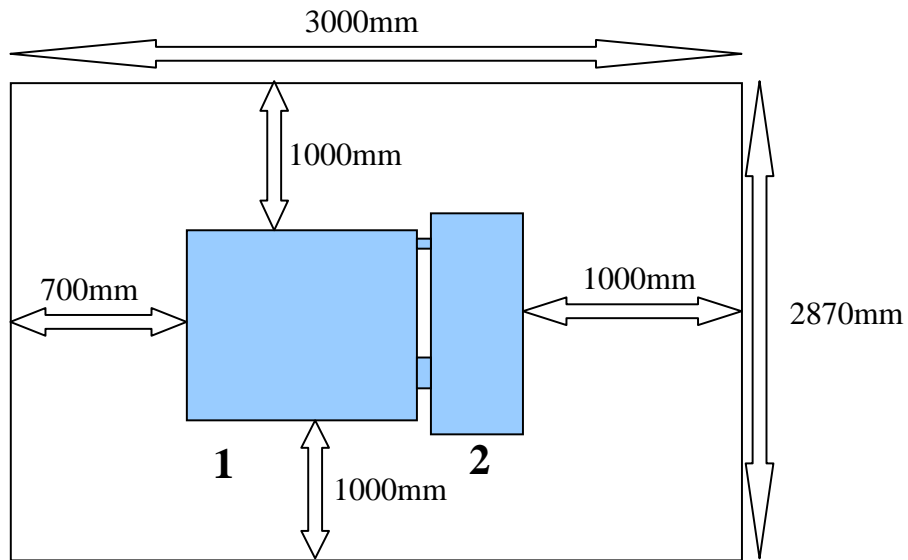

Fig. 5.1 Machine surroundings: minimal distance from walls and operator's working setting.

5.3 Mounting car wheels' holder



WARNING: The balancing machine may be delivered with an already mounted holder.

An assembled holder for car wheels with rims having a central mounting hole is shown in fig. 5.2. Before mounting the holder, clean the cone surface of the spindle (1) and the surface of the holder (2). Place the holder on the spindle so the position of the markers (3) on the spindle's snug and on the holder is aligned as shown in figure 5.2. Lastly, screw the holder onto the spindle with the bolt (4).



ATTENTION: Careful cleaning of the cone surface and maintaining the position of the holder's markers is a crucial condition for accurate measurement.

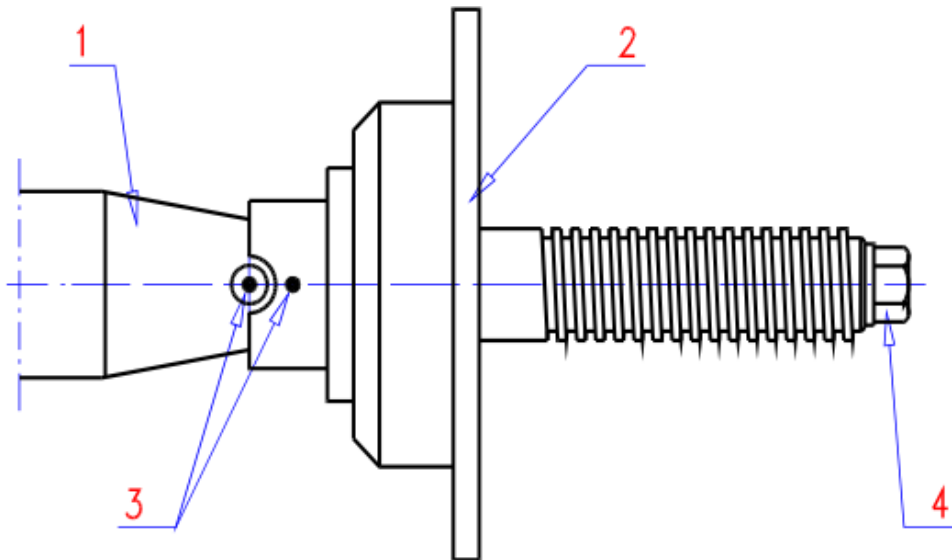

Fig. 5.2 Holder for car wheels (with no nut, cone or bushings)

5.3.1 Description of the holder's elements

The fast mounting holder was designed for car wheels with rims having a central hole. Figure 5.3 shows all of the holder's elements with their description.

5.3.2 The clamp nut

Figure 5.4 shows the clamp nut in two positions. In position *a* (clearance) one can freely move the nut along the thread. In position *b* (clamp) the nut can be screwed on the thread of the shaft.

5.4 Mounting the spike holder



ATTENTION: Spike holder is not standard equipment and – if needed – can be purchased separately.

Spike holder, presented and described in figure 5.5, is used for wheels without a central hole. Wheels having 3, 4, 5 and 6 holes can be mounted on the holder.

Due to the fact that mounting a spike holder is dependent on the balanced wheel, the whole procedure has been described in chapter 5.8.2.

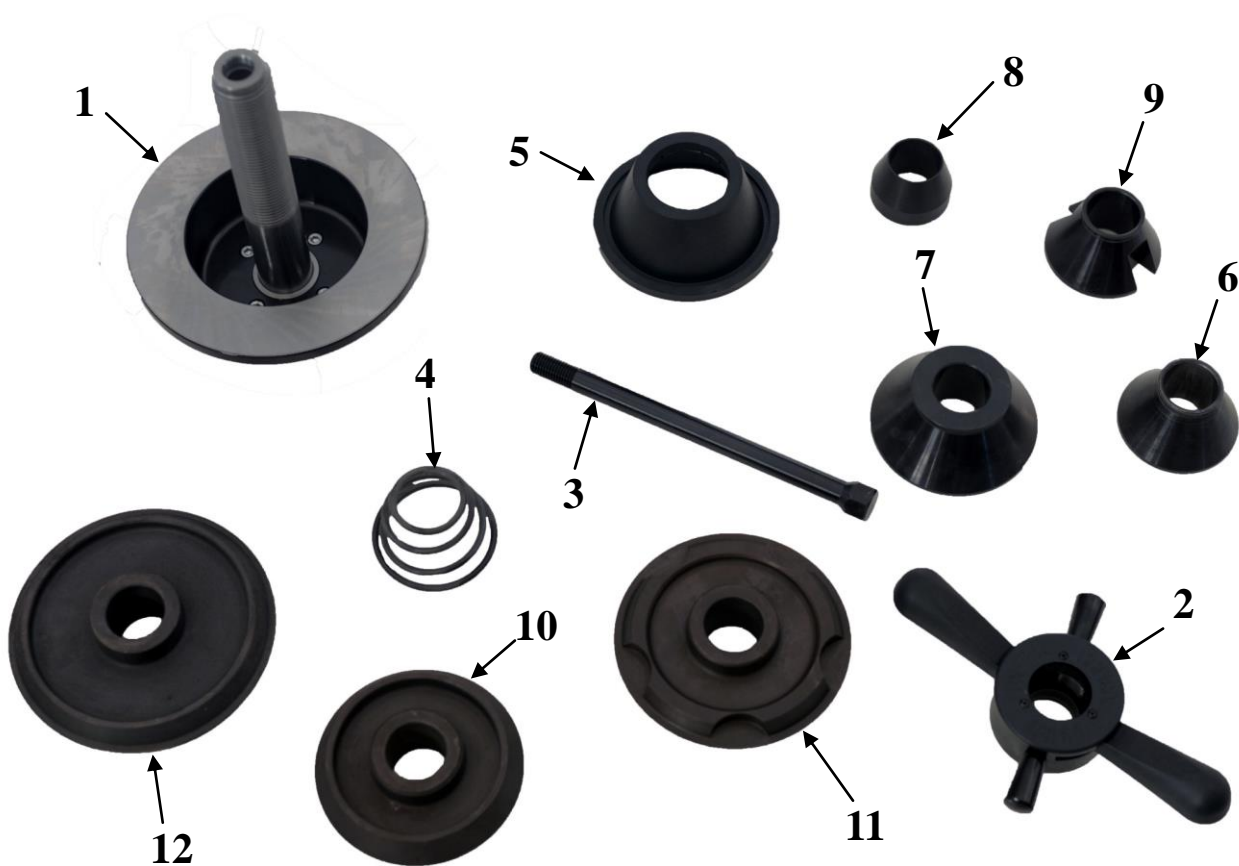

Fig. 5.3 Elements of the holder: 1: holder with flange, 2: clamp nut, 3: bolt used for mounting the holder on the spindle, 4: cone spring, 5: nut clamp, 6: centring cone no. 1, 7: centring cone no. 2, 8: centring cone no. 3*, 9: centring cone no. 4*, 10: centring cone no. 5 (110mm-125mm)*, 11: centring cone no. 6 (125mm-145mm)*, 12: centring cone no. 7 (145mm-165mm)*
* - extra equipment

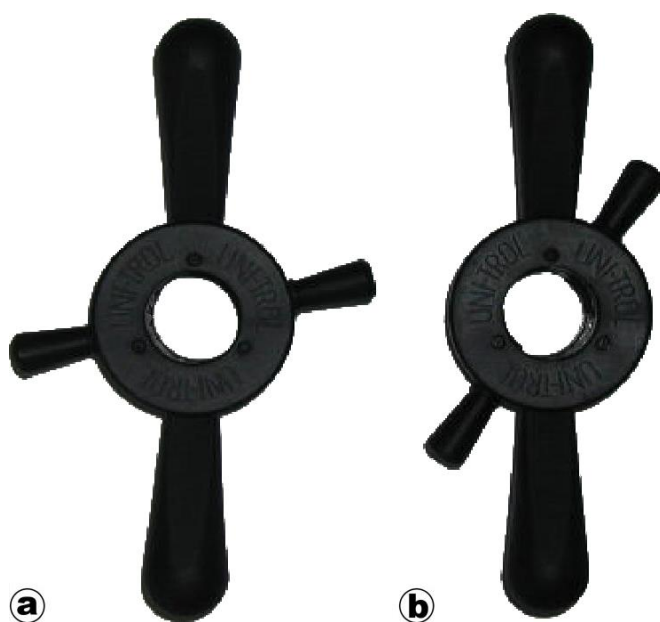

Fig. 5.4 Clamp nut a: clearance, b: clamp

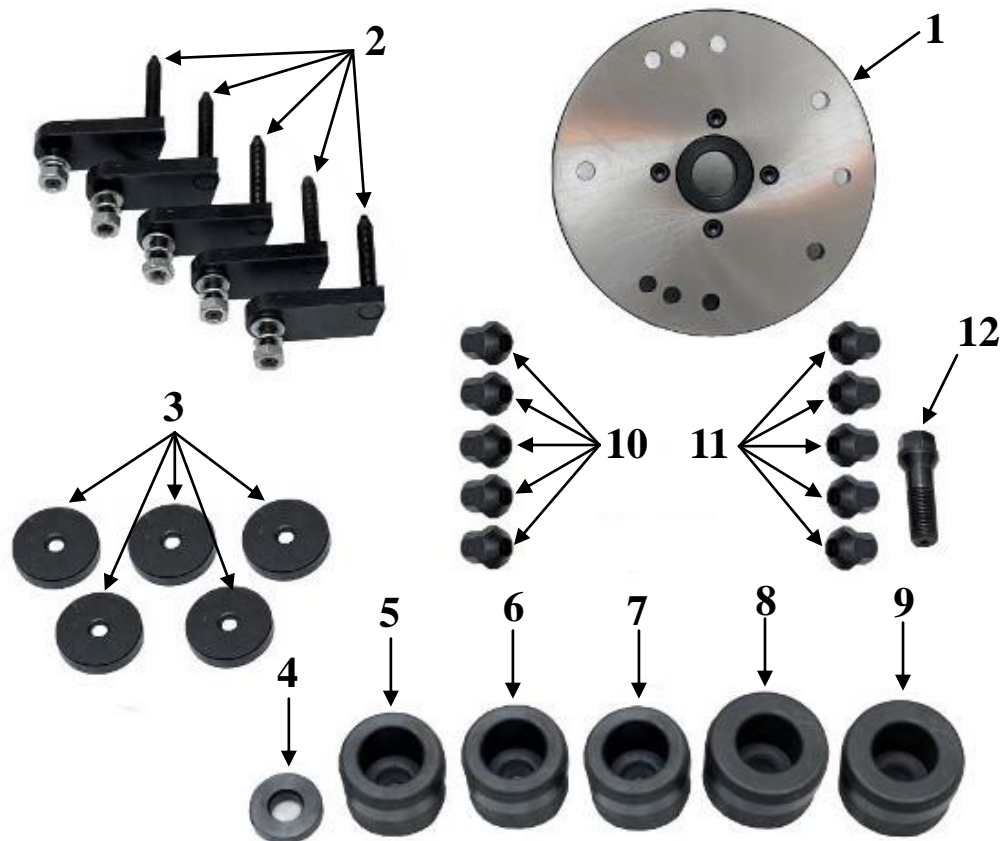

Fig. 5.5 Spike holder's elements: 1: holder's disc 2: spikes for wheel mounting 3: plates 4: pad for mounting bolt 5: centring muff $\varnothing 55$ 6: centring muff $\varnothing 56$ 7: centring muff $\varnothing 58$ 8: centring muff $\varnothing 60$ 9: centring muff $\varnothing 65$ 10: cone screw 11: spherical screw 12: bolt used for mounting the holder on the spindle

5.5 Mounting motorcycle wheels' holder



ATTENTION: Motorcycle wheels' holder is not standard equipment and – if needed – can be purchased separately.



WARNING: The balancing machine may be delivered with an already mounted holder.

Mounting motorcycle wheels' holder is very similar to mounting car wheels' holder, which was described in chapter 5.3. In fig. 5.6 the holder has been presented and all of its parts described.

For proper holder mounting, the holder's bar with a matching base (1) should be placed on the machine's spindle (1 in fig. 5.2). Secondly, the holder's axis (3) is to be screwed to the spindle using the shorter thread and tightened using a size 22 wrench.

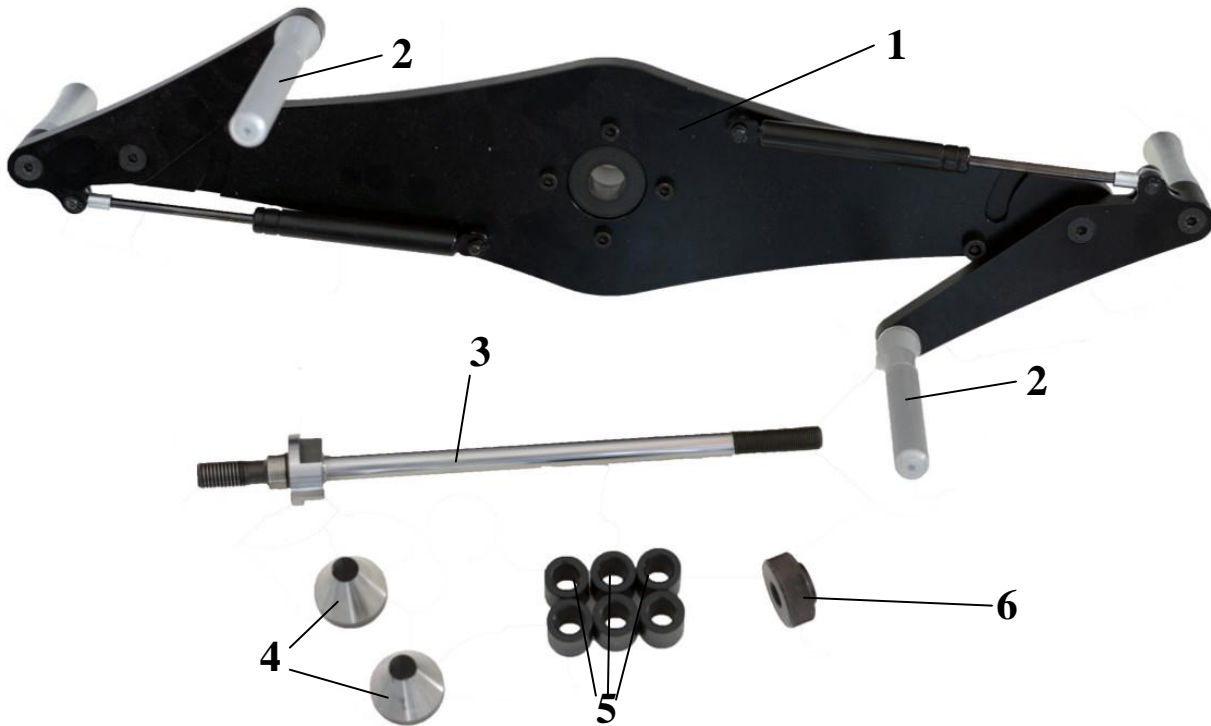

Fig. 5.6 Motorcycle wheel's holder elements: 1: holder's bar with a base, 2: tyre clamp, 3: holder's axis, 4: cone muff – 2 pcs., 5: distance muff – 6 pcs., 6: holder's screw.

5.6 Mounting the hood

The description and numeration below is based on figure 2.1.

- Unscrew all bolts from the collar (3),
- While holding the hood (1) set it in such position that holes in arm of the hood (2) are aligned with holes in the collar (3),
- Screw the arm (2) to the collar (3).

5.7 Installing and connecting LCD display

The description and numeration below is based on figure 2.1.

To install the display on the balancing machine the support (6) has to be installed first, using two screws with wide washers. After that the angle regulator (7) needs to be mounted onto the support and then the LCD display (4) attached to the regulator. Lastly, the display's power cord should be connected to the display and the signal cable to video signal socket (5).

5.8 Fixing wheels on balancing machine's holders

5.8.1 Car wheel

If there is other holder than for car wheels mounted (fig. 5.2), it should be replaced with car wheels' holder as described in chapter 5.3.

Figure 5.7 shows four stages of mounting a car wheel on the balancing machine's holder. Firstly, one has to slide the wheel on the radix of the holder (fig. 5.7a) and hang its hole's edge on the centring cone (fig. 5.7b). Secondly, place the collar of the nut in CLEARANCE position and slide the nut on the radix until there is no more space (fig. 5.7c). Then, using left hand to lift the wheel, place the thumb on the stud of the nut, move the collar to the left to CLAMP position and screw the nut pressing to the flange of the holder (fig. 5.7d).



Fig. 5.7 Mounting a car wheel in the holder.

Figure 5.8 shows two stages of dismantling a car wheel from the balancing machine's holder. In order to dismantle the wheel, place the holder's collar in CLEARANCE position (fig. 5.8a) and then turn the nut a little (fig. 5.8b). When it becomes loose, one can slide the nut and the wheel from the holder.

Construction and equipment of the holder make it possible to mount wheels with different rim shapes and different central hole diameters which is shown in figure 5.9. If using one of the centring cones (fig. 5.3) the wheel should be mounted from the outer side like in fig. 5.9a or 5.9b, without using nut clamp (5) nor cone spring (4) (fig. 5.3). If due to the rim mounted the cone is to be placed from the inner side, the nut clamp (6) should be put onto the clamp nut (2) (fig. 5.11) and spring with a matching cone slid to the handle in such manner that bigger basis is facing the machine, as presented in fig. 5.9c. Lastly, slide the wheel onto the cone and screw it firmly to the holder using



Fig. 5.8 Dismounting the wheel from the holder.

the clamp nut. All above described methods of wheel mounting have been additionally presented in figure 5.10.

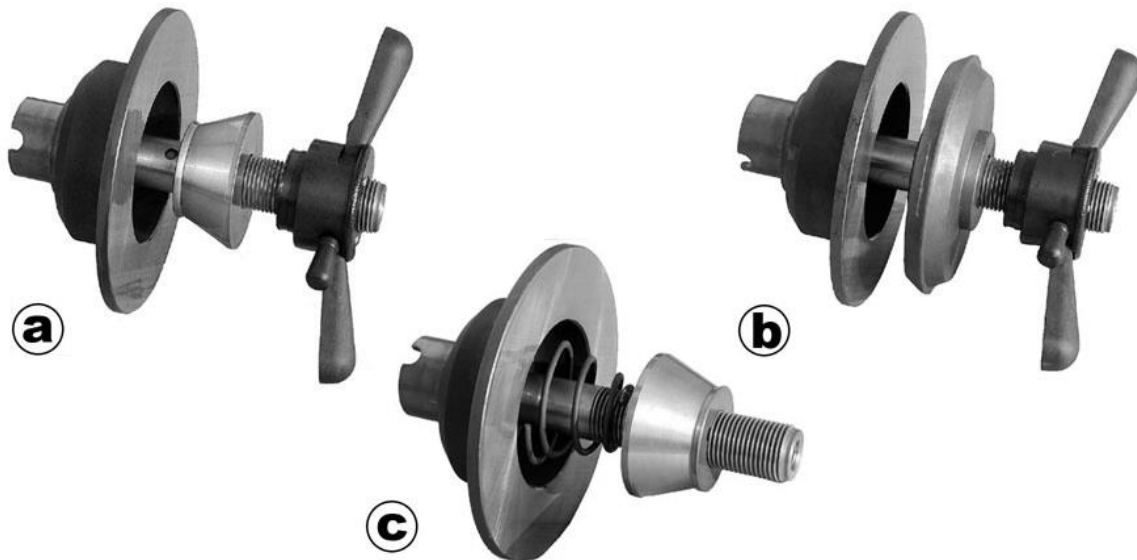

Fig. 5.9 Various methods of using the holder and its equipment.

When centring disks and cones are used for centring from the external edge of the rim, one should take the clamp off the nut. In order to do so, pull the clamp along the axis so it goes off the detent. One can gently dent it with a screwdriver. In order to put the clamp on, push it in the nut's detent.

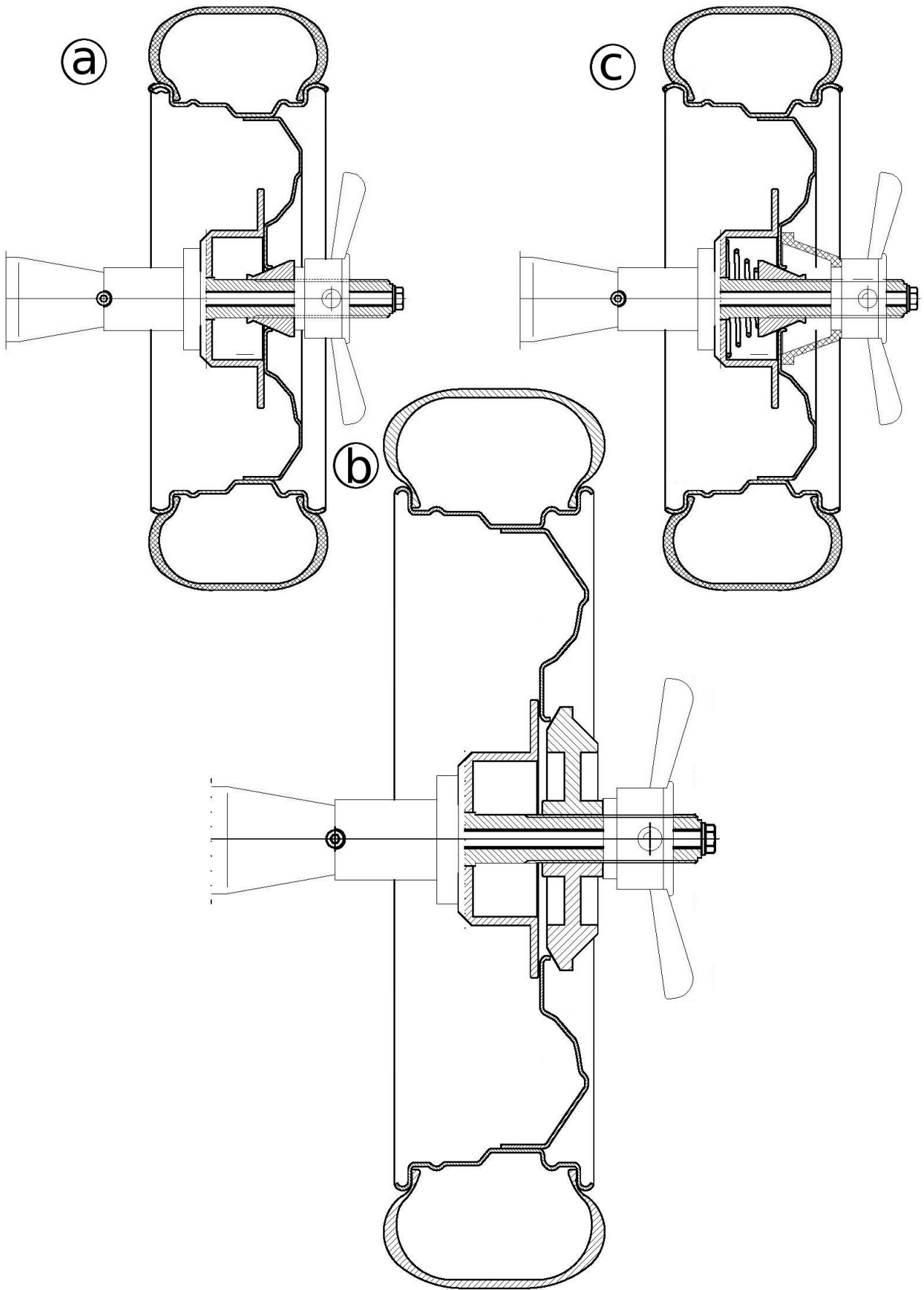

Fig. 5.10 Different ways of mounting wheels for various cones and their configurations.



Fig. 5.11 Nut with mounted clamp.

5.8.2 Car wheel in spike holder

If any holder other than the spike holder is mounted, it should be dismantled.

If the rim does not have a central hole, the spike holder should be used. Figure 5.12 presents four stages of mounting a wheel onto the described holder. Firstly, depending on the wheel, all muffs (5÷9 in fig. 5.5) should be checked to see which one fits best to the hole inside the rim. If none of them fit or there is no hole inside the rim, the pad (4 in fig. 5.5) should be used. Secondly, the disc should be mounted onto the machine's spindle and screwed using the provided bolt (12 in fig. 5.5) with the selected muff or pad, as presented in fig. 5.12a.

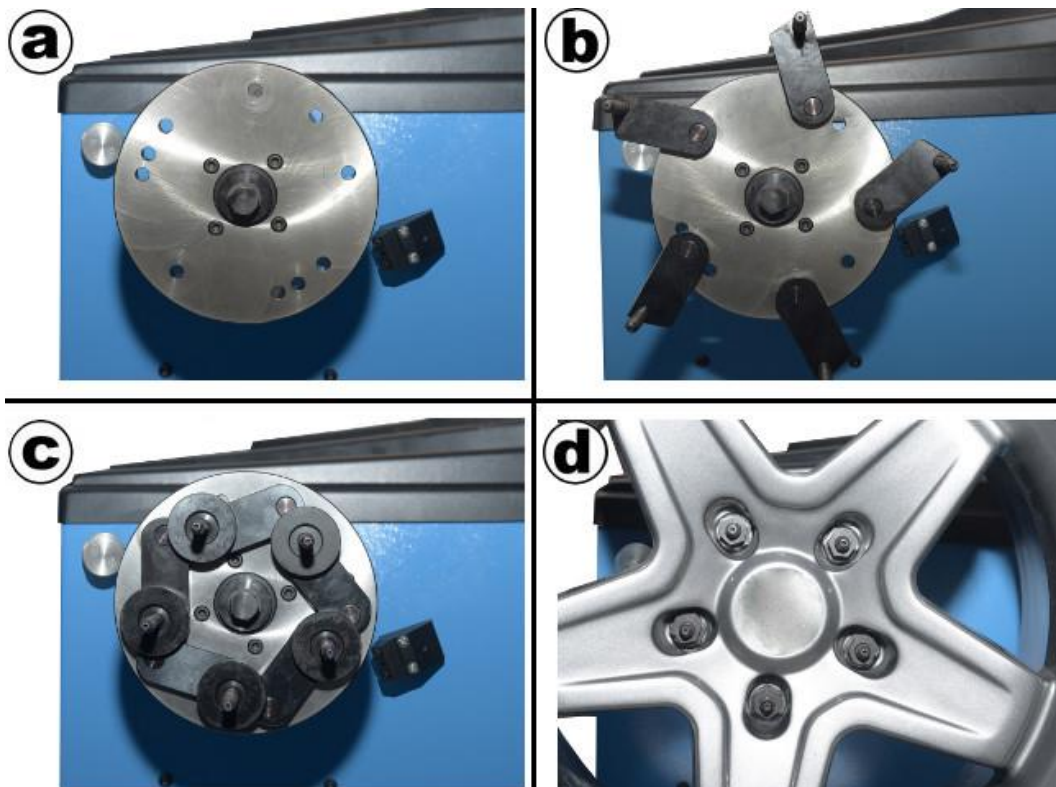

Fig. 5.12 Mounting a wheel without a central hole on the spike holder.

Depending on the number of holes in the rim, place the spikes (2 in fig. 5.5) on the disc according to the numbers imprinted on the back. For example, if the rim has 5 holes, all spikes should be

placed in holes which have the number 5 at the back of the disc (fig. 5.12b), if it has 6 holes, then 3 spikes should be placed in holes with the number 3 at the back of the disc and put into the rim through every second hole. The spikes should be screwed using the provided nuts and washers in such manner that the spikes are firmly screwed, but can be tightly rotated (first the flat washer, next the spring washer and lastly the nut). If enough free space is available, place the plates onto the spikes with the indentation facing outwards and set them in a position which makes it possible to put the wheel on the holder (fig. 5.12c).



WARNING: If any problems arise with spikes placement in relation to the rim holes during wheel mounting, the holder can be firstly set – before putting it on the spindle – on a dismantled wheel.

Depending on the female screws used in the car for wheel mounting, either cone screws (10 in fig. 5.5) or spherical screws (11 in fig. 5.5) should be applied to install the wheel on the holder (5.12d).

5.8.3 Motorcycle wheels

If any holder other than the motorcycle wheels' holder is mounted, it should be exchanged with the motorcycle holder (fig. 5.6) as described in chapter 5.5.

Figure 5.13 presents four steps of installing a motorcycle wheel in the balancing machine's holder. Firstly, the operator must make sure that tyre clamps (2 in fig. 5.6) are opened, then slide one of cone muffs (4 in fig. 5.6) on the axis (fig. 5.13a). Next, after sliding the wheel to the end of the axis and placing it on the cone (fig. 5.13b) put the other cone muff on the axis in such way that it enters the wheel's bearing. For the wheel to be tightly mounted on the holder, distance muffs (5 in fig. 5.6) should be placed after the second cone so that there is enough thread at the end of the axis for the holder's screw (6 in fig. 5.6), like in fig. 5.13c. When everything is tightly mounted and the wheel is not loose, close the tyre clamps so they touch the wheel's tyre (fig. 5.13d).



fig. 5.13 Mounting motorcycle wheel on the holder.

6. Machine programs

6.1 Activating the balancing machine

In order to activate the balancing machine, the power button (10 in fig 2.1) must be pushed in so that the light in it turns on. The machine generates a short signal and goes straight to the measurement screen. One of five screens can be shown on the LCD display:

- ▲ Main menu (procedure selection),
- ▲ Balancing program,
- ▲ Optimisation,
- ▲ Calibration,
- ▲ Machine settings.

In the following chapters all of the programs and their corresponding screens are described.

6.2 Machine's main menu

The main menu, containing the machine's programs, is presented in fig. 6.1 and makes it possible to access to one of four above described screens. To activate one of the programs set the cursor using up and down arrows on the keyboard and press *Enter*. To go back to the main menu, simply press the *Esc* key.

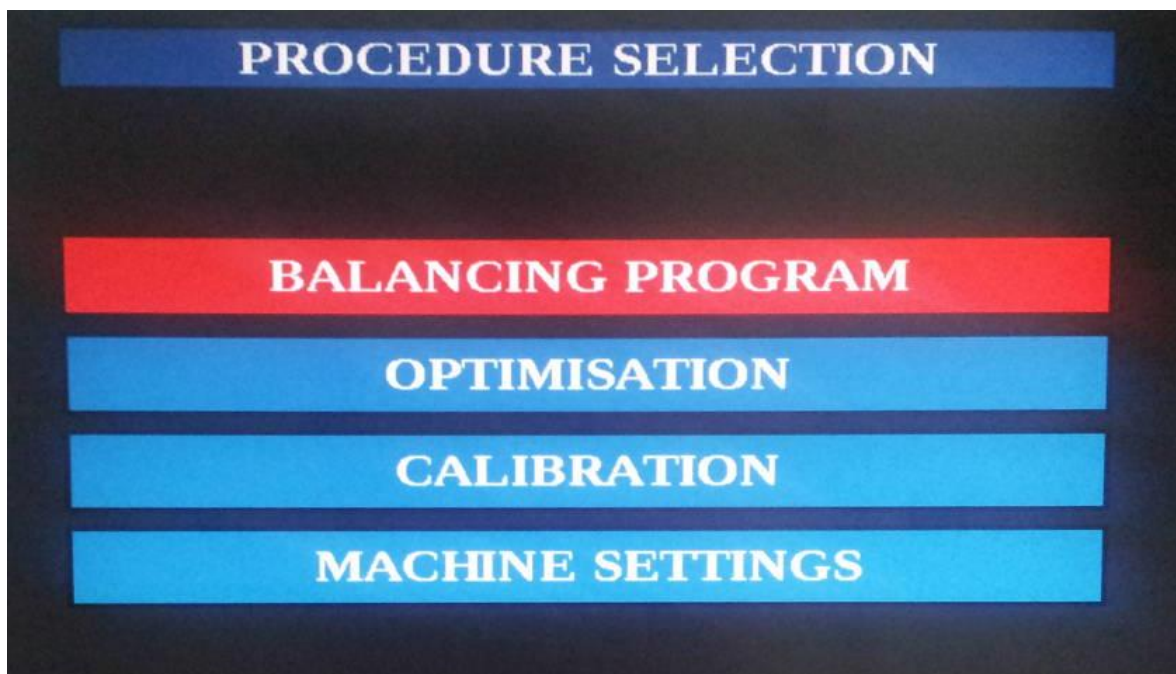

Fig. 6.1 – Main menu screen

6.3 Machine settings

For the operator's convenience, a settings menu has been provided (fig. 6.2) which gives the means of changing some of the machine's preferences and parameters. The menu consists of following submenus:

- ▲ Sound,
- ▲ Balancing,
- ▲ USG,
- ▲ Clock,
- ▲ Printing¹,
- ▲ Miscellaneous.

Available values for most of the settings are on or off (other possible values are described in remaining subchapters). If a certain option is not available, the machine will display N/A (not available).

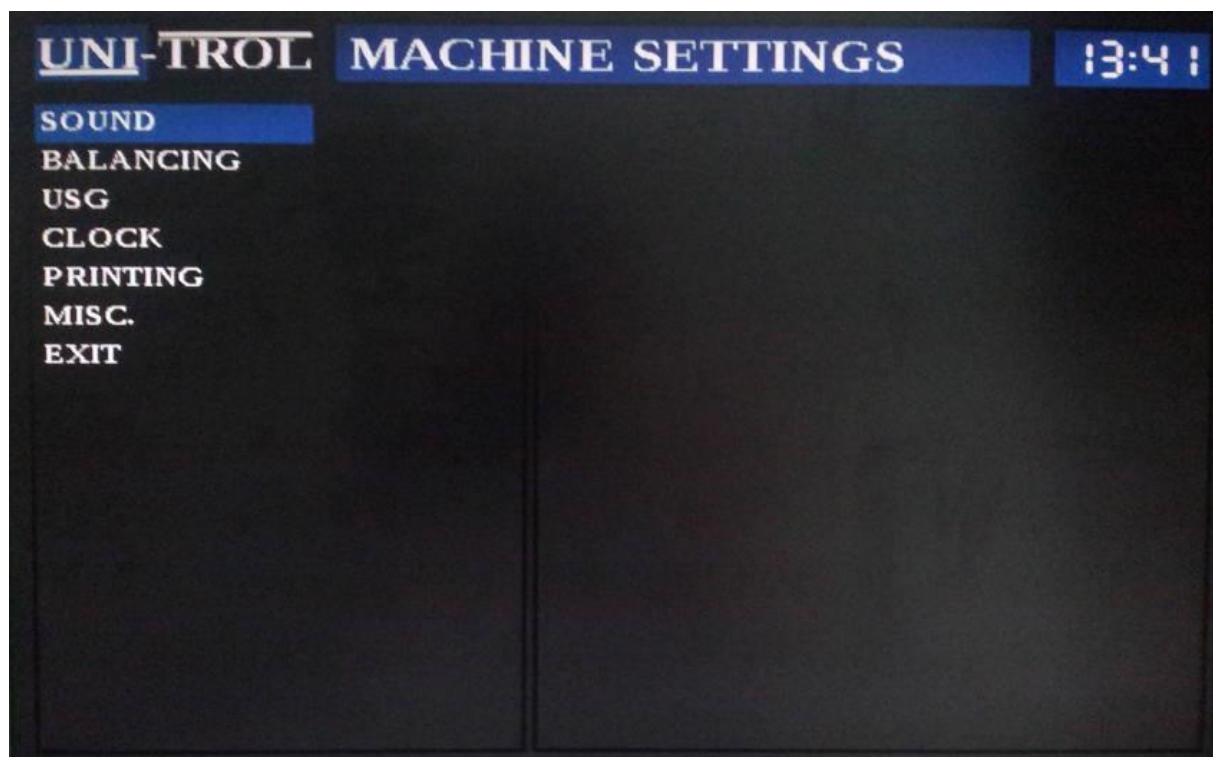

Fig. 6.2 – Machine settings screen.

6.3.1 Sound

Sound settings are for alternating volume and lector values². To change any of those, move the cursor using up and down arrow keys to Sound if it is not there and press *Enter*. Next, move the cursor on the newly displayed menu and change the value of the setting chosen using *Plus* and *Minus* keys.

¹ available only in certain machine models.

² available only in machines with one language.



ATTENTION: Turning the lector option off does not turn the system sounds off, only the lector. For operator safety, it is not possible to turn warning and signalling sounds off.

Volume has a four-step scale and should be set so the operator can hear all the signals without any problems. Default value for volume setting is $\frac{3}{4}$, lector (if available) is by default turned on.

6.3.2 Balancing

The balancing menu helps setting options regarding the measurement. It concerns displaying the result, automatic starting of measurement after closing the hood, adhesive weight placing method for modes 4, 5 and 7 in table 6.2 and a counter for all performed measurements. Displaying the result gives 2 possibilities: 1g or 5g. The option, as the name indicates, forces the machine to calculate the imbalance with accuracy of 1g or rounding to multiples of 5g for the second option. For instance, if the evaluated imbalance is 11g, then for the second option active the machine will display 10 as a result, and for imbalance equal to 14g the balancer will round it to 15. The default option is 1g.



ATTENTION: For the second option active (5g) there is a possibility of result variation between measurements. It may happen if, for example, two consecutive measurements are performed and after the first measurement the result is 10, but after the second measurement 15 – even though no additional weight has been put on the wheel. Such situation may occur if the result is close to the average of the two values. To check the result before rounding without going to settings and changing this option to 1g it is enough to hold the *Magic button* (9 in fig. 2.2) for a while, until the result starts blinking. When the button is released, the result is again displayed rounded.

Second option relates to automatic starting of measurement after closing the hood. If this option is turned on, the balancing program screen is displayed and the hood is closed, the machine will automatically invoke a measurement without the need of pressing the *Start* button. By default this option is turned on.

Third option – *Adhesive weights* – is associated with placing adhesive weight on the rim for weight placement modes 4, 5 and 7 in table 6.2. 2 options are available: *Adjuster* and *Easy mode*. Adjuster mode coerces the operator to place the weights using laser pointers. For *Easy mode*, the weights are placed **under the wheel holder's disc**, on the bottom. The adjuster's operation has been described in detail in chapter 7.

Fourth option is more of an information about performed measurements. After moving the cursor to this menu and pressing *Enter* two positions appear: “All measurements” and “Complete measurements”. The first position shows the number of **uninterrupted** measurement cycles and the second one shows the number of all cycles which resulted with no imbalance (balanced wheel).

To clear both values, press the *Memory* button.

6.3.3 USG

USG option makes the operator decide whether the ultrasonic sensor installed on the machine's hood is to measure width of a mounted wheel during the hood's closure after finishing adjuster

measurements. To activate or deactivate the ultrasonic sensor measurement move the cursor to “USG Sensor” and using *Plus* and *Minus* keys select the desired setting. By default the sensor is turned on.

6.3.4 Clock

Clock menu is either for setting or checking time and date. To change current time and/or date move the cursor to “Set time/date” using arrow keys and press *Enter*. When in time setting program, move the cursor using *L* and *R* keys to select one of the variables (from the left: day, month, year, hours, minutes), change the value using *Plus* or *Minus* keys on the keyboard and either apply changes using the *Memory* key or cancel with the *Escape* key.



ATTENTION: Machine does not check the correctness of input date. Theoretically, it is possible to input February 31st, but it may cause errors in time display on the machine programs’ screens. It is advised to thoroughly check whether all input data is correct.

6.3.5 Printing

This option is not available in this machine model.

6.3.6 Miscellaneous

The miscellaneous section provides settings for display brightness, setting all options to factory defaults, changing the language³ and displaying machine details. To adjust screen brightness move the cursor to desired option and while using *Plus* and *Minus* keys the screen’s brightness will alternate.

Bringing back factory settings sets all saved parameters to zero and brings all options to primary values which were present during machine’s first start-up.



ATTENTION: Bringing back factory defaults is an **IRREVERSABLE** operation, after which machine recalibration will be required. Use this option only in absolute necessity.

To change the current language set the cursor to the desired option and press the *Enter* key. From the list select a language of your choosing using the up and down arrow keys and press *Enter*. All the menus (and the alphabet if necessary) will change instantly.

“Machine info” option gives the operator the ability to check the balancing machine’s details, which are always helpful when contacting authorized service.

3

Changing the displayed language is only possible if lector is not available

6.4 Balancing program

The balancing program's screen has been presented in fig. 6.3. The left section contains a menu for setting wheel parameters or alternating measurement properties. Table 6.1 describes all elements of the menu as well as other sections of the screen.

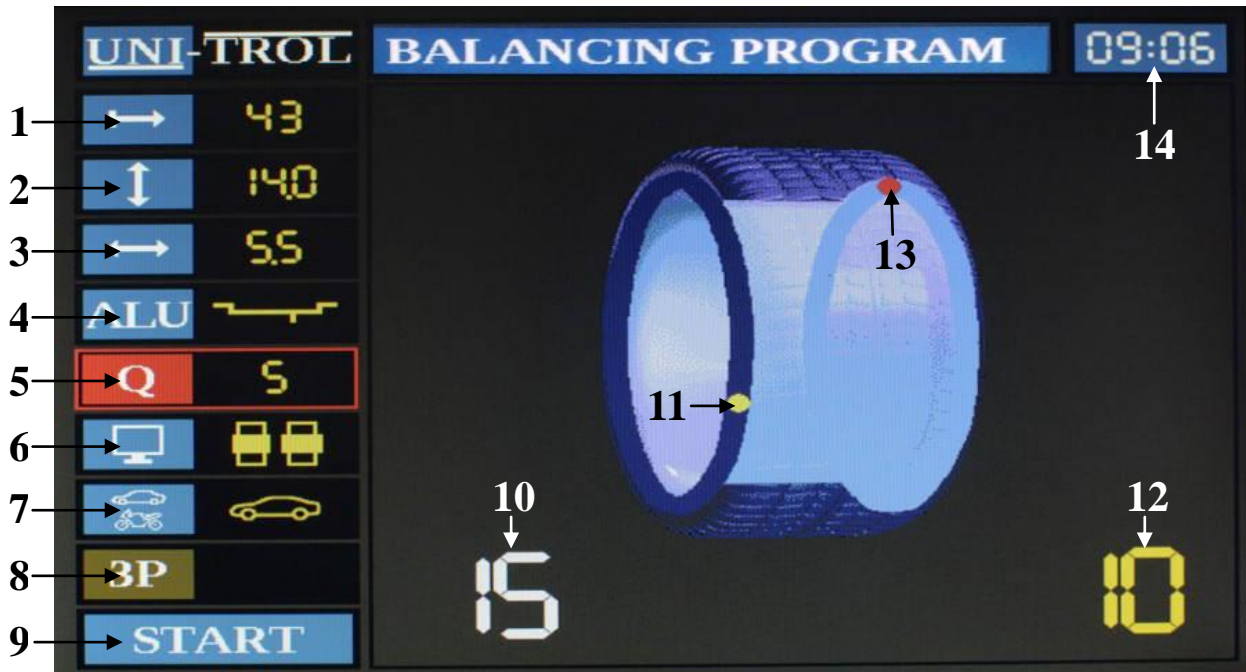

Fig. 6.3 – Balancing program screen.

Number	Description
1	Distance from the machine to balanced wheel
2	Diameter of the balanced wheel
3	Width of the balanced wheel (weight span)
4	Selection of weight placement mode
5	Changing of threshold
6	Changing screen mode
7	Measurement mode (car or motorcycle wheels)
8	“Hidden weight” program
9	Initiate measurement
10	Imbalance value of internal plane of the wheel
11	Imbalance location of internal plane of the wheel
12	Imbalance value of external plane of the wheel
13	Imbalance location of external plane of the wheel
14	Clock

Table 6.1 – Description of balancing program screen elements



ATTENTION: Before proceeding with any measurements, chapter 7 describing the adjuster principles should be read **thoroughly**. Without the knowledge of wheel parameters' inputting using the adjuster, they may be incorrectly initiated which will deteriorate imbalance calculations during a measurement.

6.4.1 Inputting parameter values from keyboard

To input wheel's distance to the machine, its diameter and width, use the arrow keys or one of shortcut keys (positions 1-3 in fig. 6.3) to set the cursor position on the chosen element. Next, using the *Plus* and *Minus* keys, set the desired value. After each button press the value will either increase or decrease, which will be signalled with a sound from the speaker. If the button is held for a longer time, the parameter value will change quicker.

6.4.2 Selecting weight placement mode

In order to select the weight placement mode, use the arrow keys or the ALU shortcut key (4 in fig. 6.3) to set the cursor position. Use the *Plus* and *Minus* keys to set the weight placement mode. After each button push the setting will change, which will be signalled with a sound from the speaker. If the key is held longer, the setting will change more rapidly. Table 6.2 presents all possible weight placement modes for car wheels (numbers 1-5) and two motorcycle wheel modes (numbers 6 and 7).



ATTENTION: It may happen that instead of red weights in the ALU section on the screen question marks are present. It is an automatic weight placement program which is described in detail in chapter 7.2.

No	Setting	Description
1		Balancing a car wheel with hammered weights on both sides of the rim.
2		Balancing a car wheel with adhesive weights on both sides of the rim.
3		Balancing a car wheel with hammered weight on internal plane and adhesive weight on external plane of the rim.
4		Balancing a car wheel with adhesive weight on internal plane and adhesive weight inside the rim.
5		Balancing a car wheel with hammered weight on internal plane and adhesive weight inside the rim.
6		Balancing a motorcycle wheel with adhesive weights on both sides of the rim.
7		Static balancing of a motorcycle wheel.

Table 6.2 – Description of possible weight placement modes.



ATTENTION: Changing weight placement modes in optimisation and calibration programs **is not possible!**

6.4.3 Changing of threshold

Threshold level is used for hiding small values of imbalance. Setting a higher threshold increases the machine's tolerance. In order to set threshold level move the cursor to the threshold setting or press the shortcut key (5 in fig. 6.3). Next, using the *Plus* or *Minus* keys, set the desired value. After each key press the value changes, which is also signalled with a sound. If *Plus* or *Minus* is held longer the threshold changes quicker. Available values are 2g, 5g and 10g. When one of there are set, all imbalance values below the threshold are set to 0g.



ATTENTION: If 2g option is not available, it means that result round-off in machine settings is set to 5g. This option has been described in detail in chapter 6.3.2.

6.4.4 Changing screen mode

In order to change the screen mode, move the cursor using up and down arrow keys to position 6 from fig. 6.3. Next, using *Plus* or *Minus* keys, change this option to one of 2 possibilities. Figure 6.3 presents an option with a wheel on the screen and figure 6.4 shows the simplified display mode.

Wheel displaying mode shows imbalance positions using a yellow dot moving around the rim's edge. If the wheel is close to one of the positions of imbalance, the imbalance result changes its colour from white to yellow. If the wheel is exactly at the imbalance position, the dot changes its colour from yellow to red (external plane in fig. 6.3).

In the simplified displaying mode the imbalance position is shown using arrows on the screen as well as the colour intensity of the imbalance value. If both arrows are directed upwards, it means that the wheel has to be revolved forward. If the arrows are both directed downwards, the wheel needs to be reversed. Depending on the colour (and its intensity) of the imbalance value, the greener the colour the closer the wheel is to the imbalance position. The colour becoming more red indicates receding from the imbalance point. If the arrow above imbalance value points downwards and the arrow below imbalance value points upwards (as in fig. 6.4 for external plane), the imbalance position is at the top of the wheel (if the frame on the top changed its colour to red) or at the bottom (if the frame at the bottom changed its colour to red). If both arrows point outwards in opposite directions, the imbalance position is exactly on the other side of the wheel and it has to be rotated 180°.

6.4.5 Selecting machine's measurement mode

Depending on the wheel type the operator wishes to balance, the measurement mode should be set. In order to do so, move the cursor using arrow keys to position 7 from fig. 6.3. Next, using *Plus* or *Minus* button, change the measurement mode to one of 2 following values: car wheels or

motorcycle wheels. After each key press the value changes, which is also signalled with a sound.

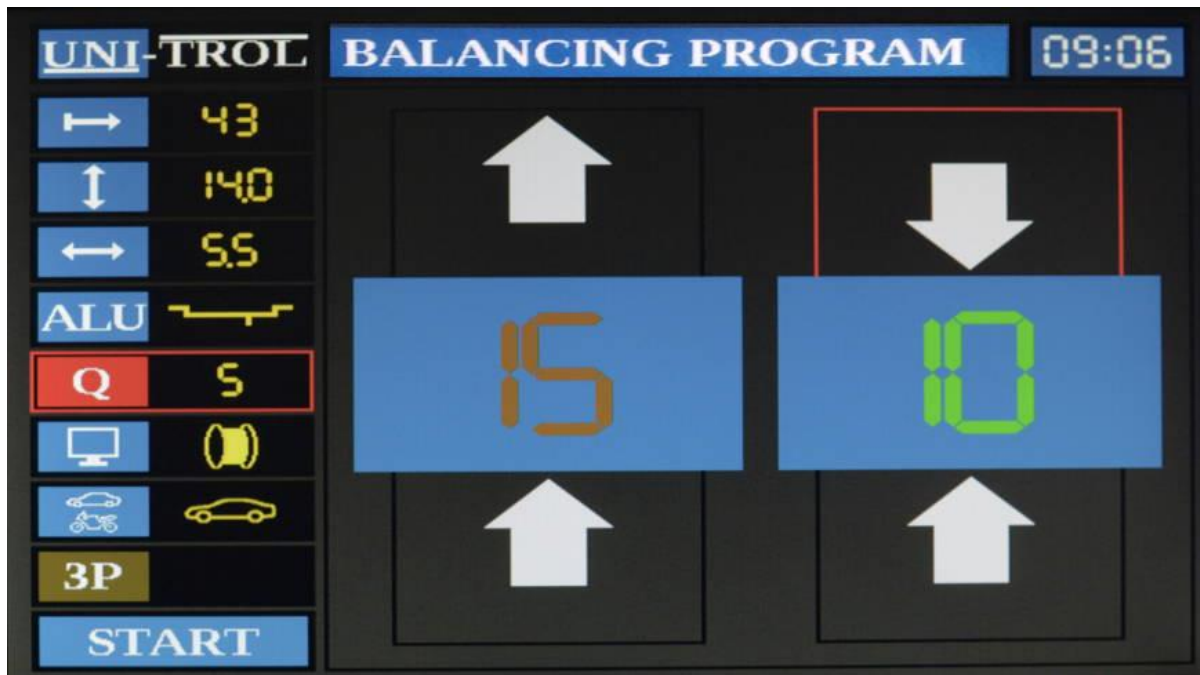

Fig. 6.4 – Balancing program screen – simplified mode.

6.4.6 “Hidden weight” program

The “hidden weight” program breaks down a single imbalance point. It is only available for weight placement modes 4, 5 and 7 from table 6.2. This function is used to break down the value and position of imbalance correction into two separate values and points so that the adhesive weights can be hidden behind the rim’s spoke thanks to which they are not visible from outside (for a car wheel, modes 4 and 5) or split the imbalance so that it is possible to omit the spoke, which is exactly in the weight placement point (for motorcycle wheels, mode 7).



ATTENTION: When selecting new positions for adhesive weights behind the stokes it is important that the new places are located on both sides of the old imbalance position. A situation where both new places are, for example, on the left side of the previous imbalance point **cannot happen**.

To activate the “hidden weight” program, move the cursor to icon 8 from fig. 6.3 and press *Enter* or directly run the function by pressing the “hidden weight” shortcut button (17 in fig. 2.2). A simplified display mode is shown, but split into three sections and “SELECT POINT 1” caption appears at the top of the screen, as presented in fig. 6.5.



ATTENTION: As long as icon 8 from fig. 6.3 is brown, the “hidden weight” program is inactive. This program activates automatically only for weight placement modes 4, 5 and 7 and imbalance values above 5g.

The left part with imbalance value corresponds to internal plane of correction and the central part to external correction plane. To choose the first point where the first weight is to be placed, find the current imbalance position by revolving the wheel in the direction pointed by the arrows (downwards in fig. 6.3). If the imbalance position is on the top, the machine signals it with a sound,

arrows point inwards and the upper frame becomes red. At this point the machine shows the original imbalance position.

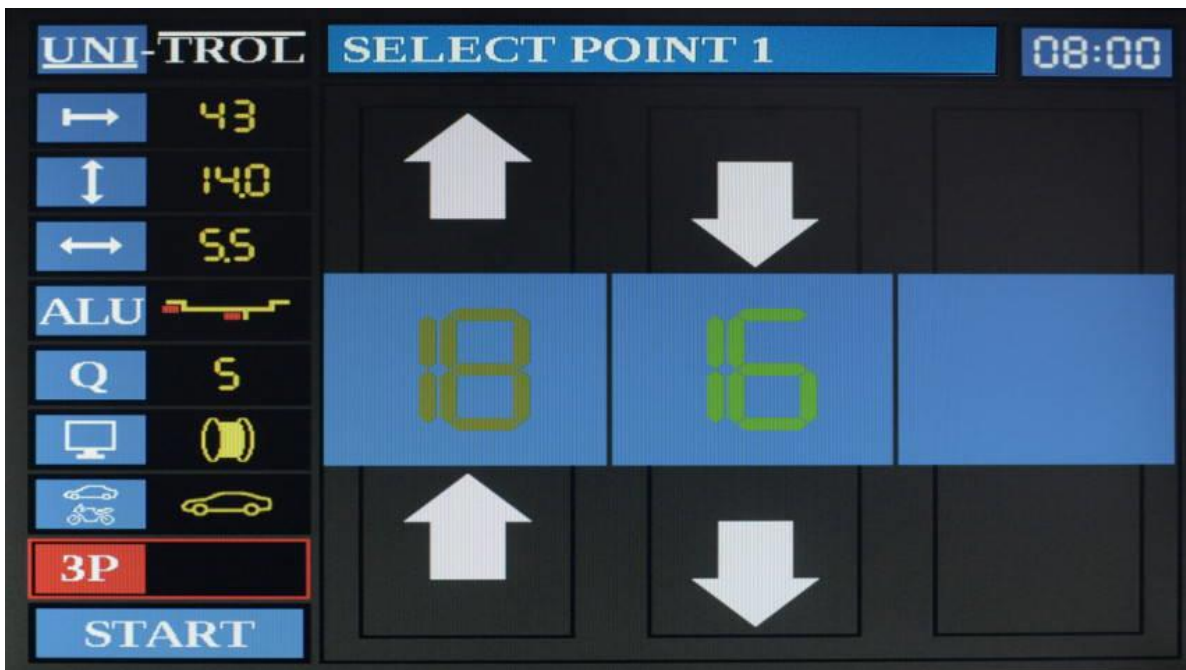

Fig. 6.5 – Screen of “hidden weight” function – selecting the first point.

Having the imbalance position at the top, set the wheel so that one of the selected stokes (behind which the new weight is to be placed) is at the top. If the stoke reaches the desired position, press the *Plus* button.



ATTENTION: If after pressing the *Plus* key the machine gives a short signal and the caption „SELECT POINT 1” blinks red, it means that the new weight place is too close to the original imbalance correction point and the wheel should be turned a little more.

After approving of the first position (stoke), the caption on the top of the screen will change to “SELECT POINT 2” and the imbalance values as well as arrows will disappear, as shown in fig. 6.6. To select the second position, set the wheel so that the second stoke (placed on the other side of the original imbalance position) is located at the top, and press the *Plus* key.



ATTENTION: If after pressing the *Plus* button the machine gives a short signal and the caption “SELECT POINT 2” blinks red, it means that either the second position is too close to the original imbalance position or the first selected point, or both selected points are on the same side of the original imbalance position. In such case the second point’s position should be changed.

After selecting the second point, three imbalance values are presented on the screen, just like in fig. 6.7. The left position contains the value for the internal imbalance correction plane and both the central and right positions contain values of newly selected positions behind stokes (or omitting the stoke for a motorcycle wheel). A weight should be placed on the rim for all of the correction planes, after which a control measurement should be performed to check if the weights have been properly placed and whether the wheel is balanced.



Fig. 6.6 – Screen of “hidden weight” function – selecting the second point.

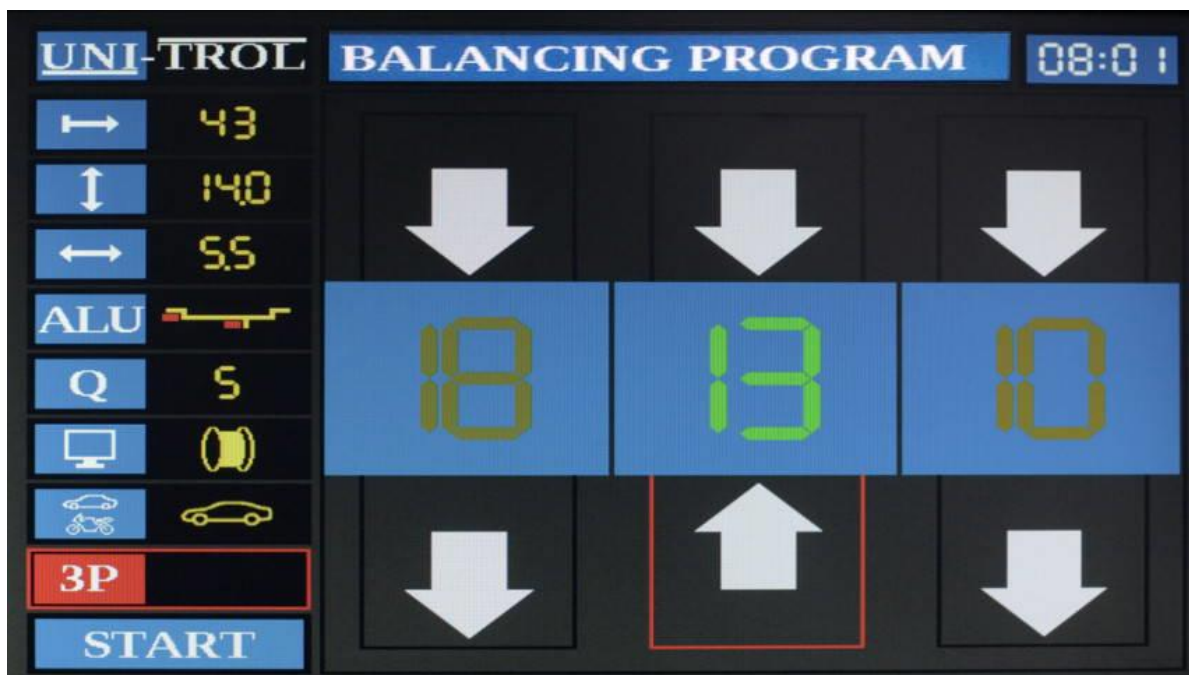

Fig. 6.7 – “Hidden weight” function – final screen.

6.4.7 Initiating the measurement



ATTENTION: Before proceeding with the measurement, chapter 7 regarding the adjuster should be **thoroughly** read. Without proper know-how of its operation, wheel parameters may be incorrectly input which will deteriorate imbalance calculations.

The measurement cycle can be initiated in 3 different ways:

- ⤴ Closing the hood (if “Autostart” option described in chapter 6.3.2 is active),
- ⤴ Pressing the *Start* key with the hood closed,
- ⤴ Moving the cursor to position 9 from fig. 6.3 and approving by pressing *Enter*.

If the hood is not closed, the measurement will not start. After pressing the *Start* button with the hood opened the machine will give an error (if lector option is available and activated it is a “*close hood*” message, otherwise a short sound signal). After the measurement finishes, imbalance values appear together with their positions where to place the weights. After placing the weights on the rim, a control measurement should be performed to check whether the imbalances have been cancelled out.

If after the control measurement it turns out that not all imbalance has been abolished (which can be a result of poor quality weights or operator’s mistake), the machine will give hints – if lector is available and activated – how to correct the position of the weight. If the lector option is not available (or turned off), the correction should be performed according to the below described scheme:

- ⤴ if the new imbalance position matches the first position or is only slightly shifted, *the weight should be increased* (fig. 6.8a),
- ⤴ if the new imbalance position is on the other side of the first imbalance location or slightly shifted from that location, *the weight should be decreased* (fig. 6.8b),
- ⤴ if the new imbalance position is to the left or right of the first imbalance location (fig. 6.8c for left and fig. 6.8d for right), *move the weight* towards the new location, regardless of the first position whether it is no the top or bottom of the wheel.

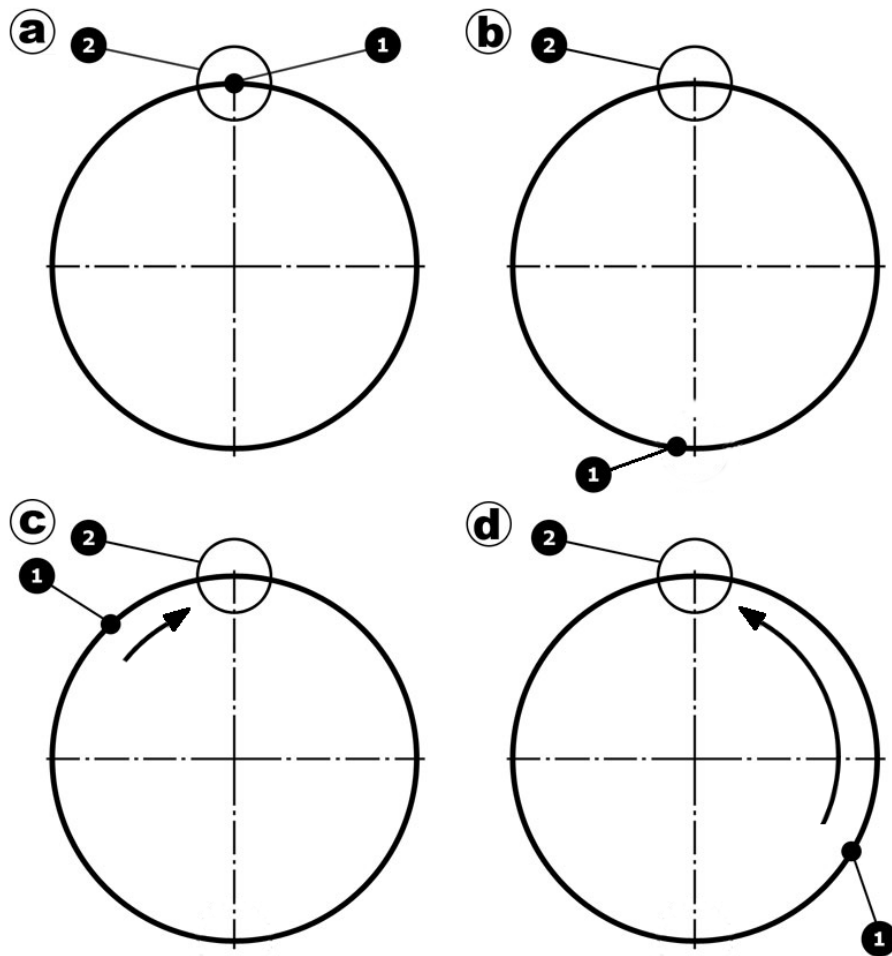

fig. 6.8 – Weight placement correction: 1: firstly placed weight
2: new imbalance location

6.4.8 Automatic wheel positioning

The moment when the measurement cycle is over, imbalance values are displayed and the wheel stops rotating, the machine can automatically direct the wheel on one of the two imbalance positions, depending on the operator's choosing. The operator may look for a proper weight while the balancer rotates the wheel to the specified plane's imbalance location.

To start the automatic wheel positioning procedure to one of imbalance locations, the *L* or *R* key has to be pressed for internal (left) or external (right) side of the wheel, respectively. In a short moment the wheel will be positioned in the vicinity of the selected imbalance location.



ATTENTION: The automatic wheel positioning procedure can only be initiated when the wheel fully stops. If the wheel is still in motion, buttons *R* and *L* are inactive. There is also no possibility of changing a previously selected location during positioning.

6.5 Optimisation

Optimisation is a control test of a wheel providing rim and tyre alignment checking to ensure that imbalances coming from both cancel each other out. It helps diminishing the imbalance of the wheel and using smaller weights. Imbalances of both rim and tyre are performed in 2 measurement cycles and the result takes both correction planes into account.



ATTENTION: Optimisation is to be performed as a preliminary operation to wheel balancing using weights.

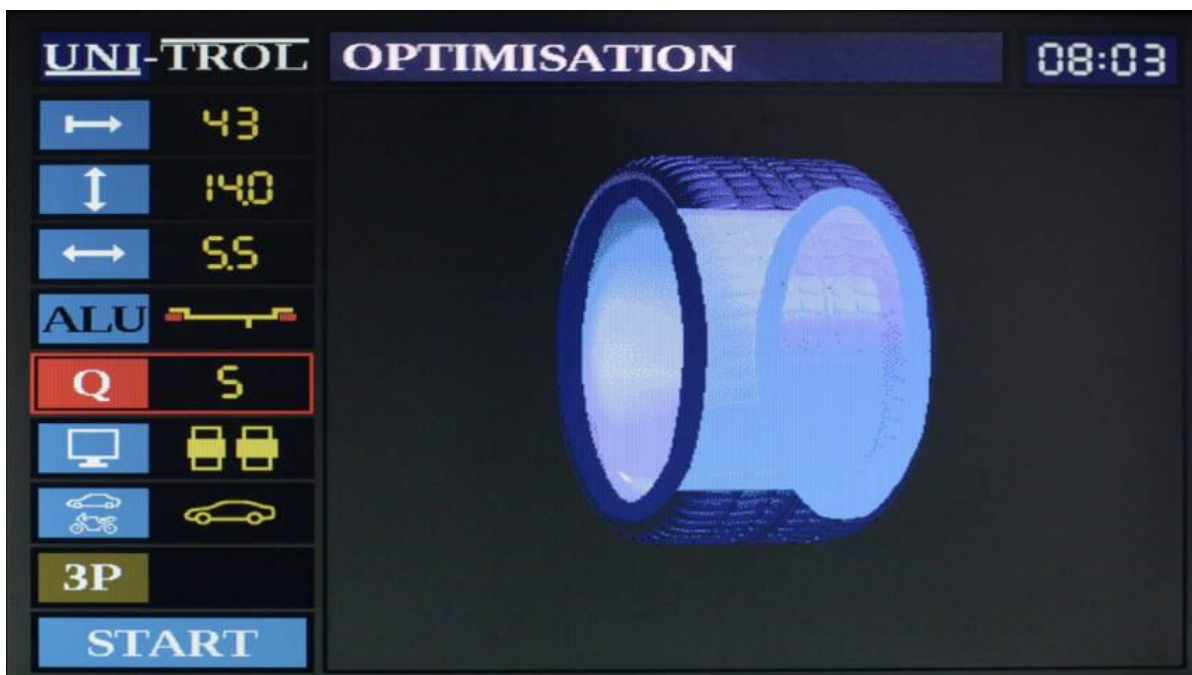

Fig. 6.9 – Optimisation screen – start-up.

To begin optimisation, go to the main menu (fig. 6.1) and select the *Optimisation* program if it has not been activated yet. The screen presented in fig. 6.9 will appear on the display. Place **just the**

rim in the machine's holder in a specific way, so that later it can be mounted exactly the same – e.g. such that the valve is located at the same position as the markers on the spindle's snug and on the handle (3 in fig. 5.2).

After pressing the *Start* key for the first time, the caption at the top of the screen changes to “Measure bare rim” (fig. 6.10). Next, after closing the hood and pressing *Start* key again, a measurement cycle for the mounted bare rim begins. When the measurement is over, the caption changes to “BARE RIM IMBALANCE”, and on the bottom of the screen imbalance values appear with the eventual correction locations (fig. 6.11).



ATTENTION: If optimisation is to be correctly performed, these imbalance locations **CANNOT BE CORRECTED!** They are only displayed for information purposes to help determine the actual state of the rim.

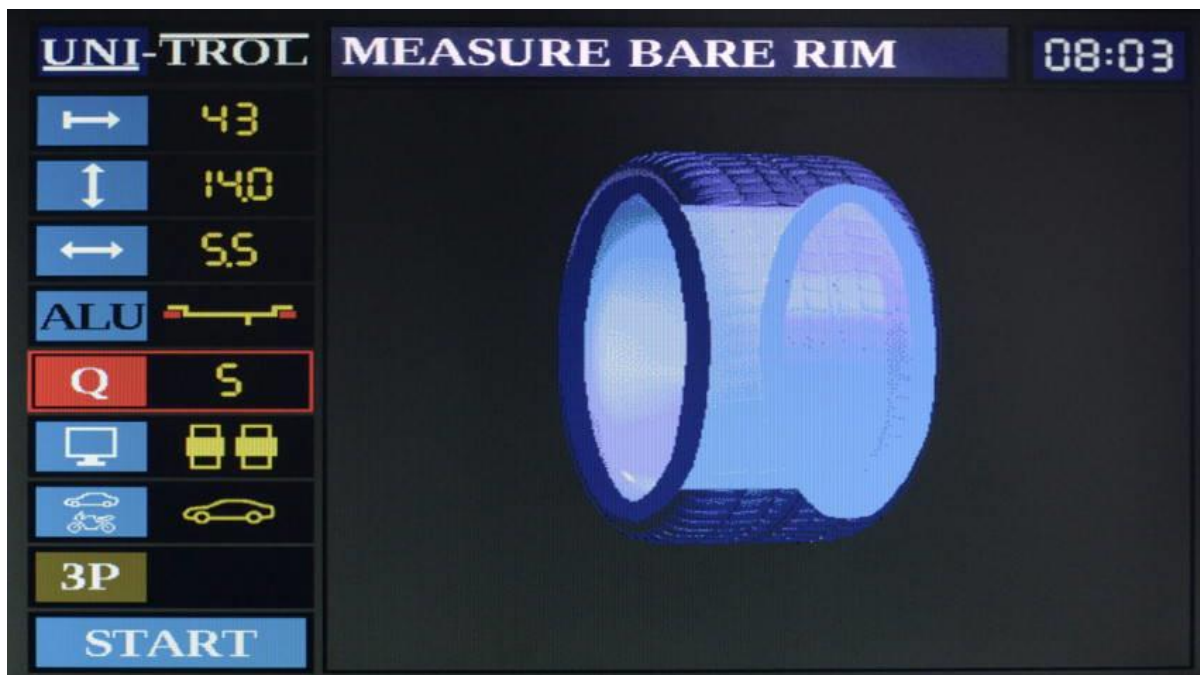

Fig. 6.10 – Optimisation screen – bare rim measurement.

After pressing the *Start* button, the rim imbalance information is deleted and the caption changes to “MEASURE TIRE AND RIM” (fig. 6.12). Before initiating the second measurement, the rim should be dismounted remembering its setting on the holder so that the wheel can be placed in exactly the same way. Afterwards place a tyre on this rim, inflate and mount the wheel in the same manner as before (for the example given above – with the valve at the same position as the markers on the spindle). Subsequently, after placing the wheel on the holder, close the hood and press *Start* to initiate the second measurement cycle.



Fig. 6.11 – Optimisation screen – bare rim imbalance.

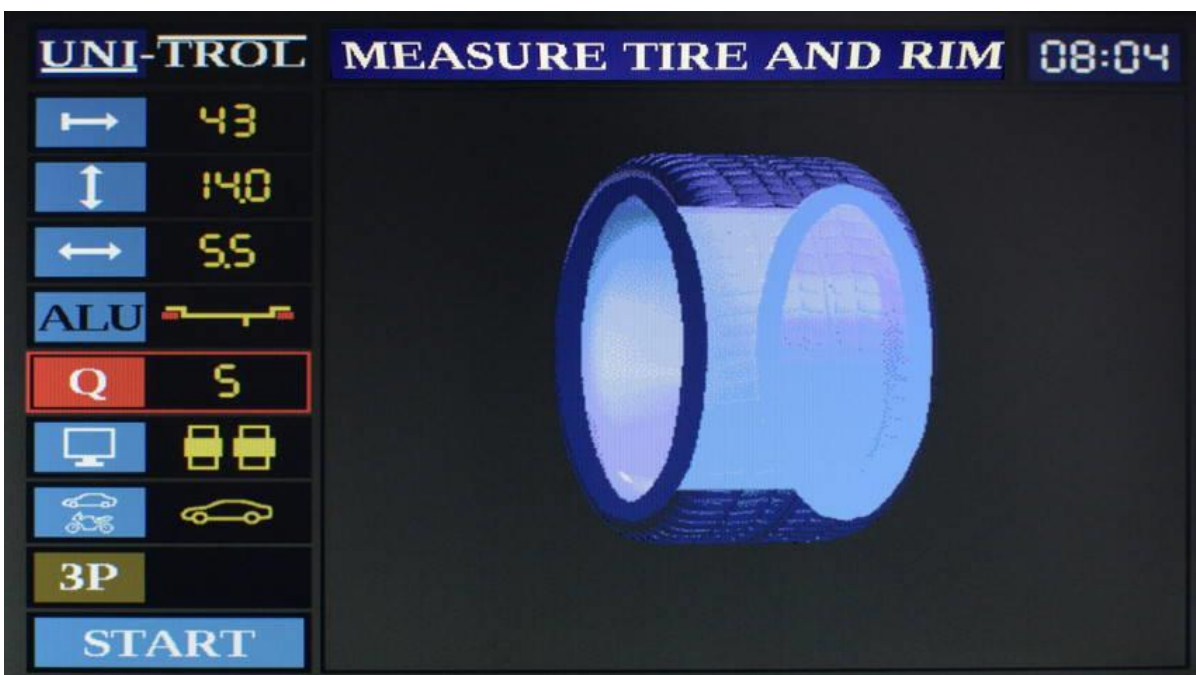

Fig. 6.12 – Optimisation screen – tyre and rim measurement

When the balancing machine finishes the second measurement cycle for the tyre and rim, a new caption “PROFIT” appears and at the bottom of the screen a value is displayed informing how many grams fewer are to be used to balance the wheel after aligning the tyre and the rim according to the positions given by the machine. After marking (using, for example, a piece of chalk) both positions on the tyre and the rim – on the external side – dismount the wheel, align both marked positions so that they are in the same place and inflate the wheel. Finally, go to the main menu using the *Escape* key and select the balancing program to balance the wheel.

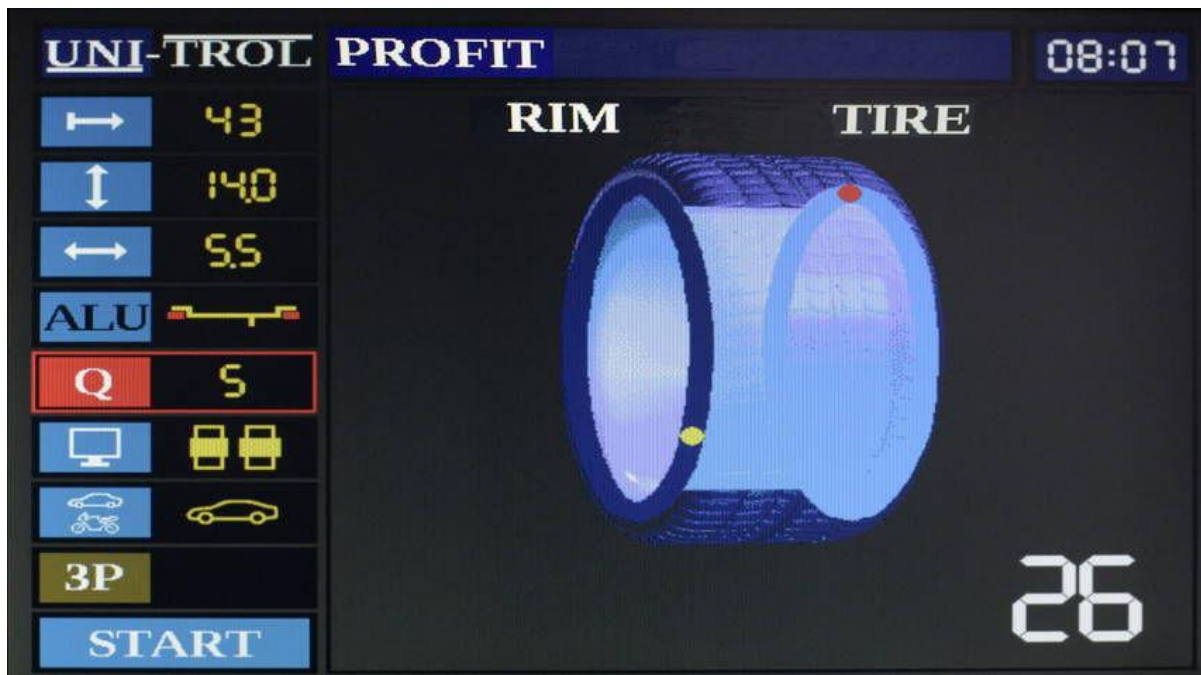

Fig. 6.13 – Final optimisation screen – optimisation gain.

6.5.1 Optimisation special cases

If the machine goes directly from screen presented in figure 6.11 to the screen presented in figure 6.13, or the optimisation gain is equal 0, it means that moving the tyre with respect to the rim will not give any improvement allowing diminishing the used weights for wheel balancing. Such situation can take place if:

- ⤴ Rim is balanced (the rim and tyre screen does not appear),
- ⤴ Tyre is balanced,
- ⤴ After fixing the tyre on the rim the imbalances cancel each other out on the first attempt.

6.6 Calibration



WARNING: Each sold machine is **already calibrated!** Calibration is advised only in a situation where there exists a probability of machine decalibration (if e.g. displayed imbalance values do not reflect actual values).

Calibration program is for tuning the wheel balancing machine in case the operator doubts the correctness of the machine's operation. The screen of the calibration program is presented in fig. 6.14. Entering the calibration program is signalled with a sound (or – if lector options is available and activated – the machine will say “calibration”) so that the user knows that he may decalibrate the machine. Most of the positions in the left section of the screen are the same as for the balancing program. Same as in the optimisation screen, weight placement option is not available. Additionally, instead of the “hidden weight” icon, a calibration mode selection icon is present.

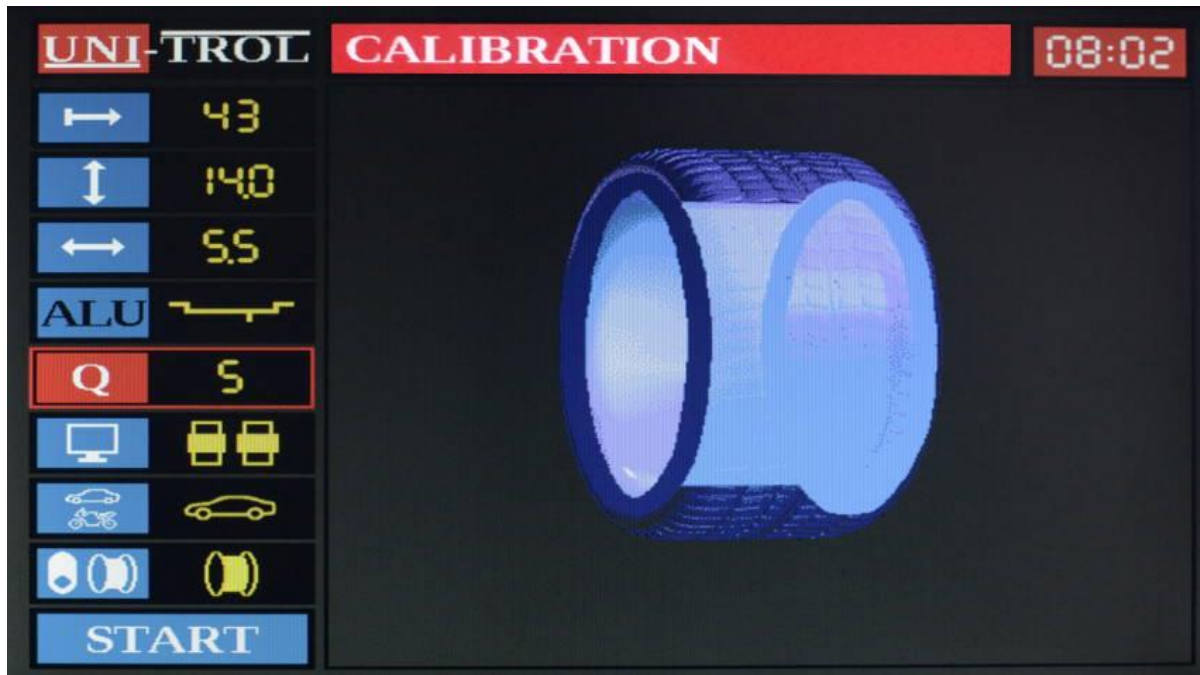

Fig. 6.14 – Calibration program screen

6.6.1 Calibration mode selection

All machines are equipped with a calibration device. It gives the operator an option to choose between either calibrating with a wheel or the calibration device. In figure 6.14 one can see a new icon in the “hidden weight” icon’s place: calibration mode selection. The currently displayed icon shows the active calibration mode. Using the *Plus* or *Minus* button choose the desired option. If the calibration device has been selected, there is no possibility of changing distance, diameter and width parameters of the wheel, because these are permanently set for the device for best calibration results.

6.6.2 Calibration using the device

After selecting calibration mode (chapter 6.6.1) put the calibration device on the car wheels’ holder, close the hood and press *Start*. When imbalance values 0 for internal and 80 for external correction planes appear, the machine is calibrated and ready to balance wheels.



WARNING: If the *Start* button is pressed after the calibration cycle is over, the machine goes to the main menu screen to prevent decalibrating the machine by mistake.

6.6.3 Calibration using a wheel

After selecting calibration mode (chapter 6.6.1), mount a **BALANCED** wheel (or with the least possible imbalance) with known parameters. Hammer an 80g weight on the external correction plane and set the real wheel parameters. Finally, close the hood and push the *Start* button. When imbalance values 0 for internal and 80 for external correction planes appear, the machine is calibrated and ready to balance wheels.



WARNING: If the *Start* button is pressed after the calibration cycle is over, the machine goes to the main menu screen to prevent decalibrating the machine by mistake.



ATTENTION: If the wheel used for calibration is not balanced, the machine will not calibrate correctly. Even though it may seem that the cycle has successfully completed, consecutive measurements will show that the obtained imbalance values differ from the real ones.

6.6.4 Balancing a wheel before calibrating with it

To balance a wheel before using it for calibration go to the balancing program, set the threshold to the lowest value and start a measurement. If there is no imbalance and two zeroes appear, the wheel is balanced and may be used for calibrating the machine. Otherwise it should be balanced until a control measurement shows zero-valued imbalance results. Only then calibration can be performed as described in chapter 6.6.3.

7. Adjuster



ATTENTION: Measuring the diameter value with the adjuster gives **true actual** values, which is why the value displayed on the screen may differ from the one marked on the rim.

The adjuster is a tool for automatic distance and diameter parameter determination and also for weight selection modes 4 and 5 from table 6.2 width of the wheel. Depending on whether the weight selection mode has been selected prior to the adjuster measurement or not selected at all, machine displays parameters in two ways. Both of them are correct. The distinction has been made so that the operator can choose the most convenient method of parameter evaluation which suits him best. All of it has been described below in chapters 7.1 and 7.2. Additionally, the machine is capable of suggesting what weight placement mode to apply according to the way the balancing machine's operator uses the adjuster. It is described in detail in chapter 7.2.



WARNING: To start determining wheel parameters from the beginning, press the *Stop* key. If the lector option is available and active, the machine signals it with a “*Clear*” message.

To properly perform a parameter measurement cycle with the adjuster, move the cursor to distance or diameter using either up and down arrows or the corresponding shortcut keys. When the adjuster is protruded, a laser line and a dot appear on the rim. Independent of whether the weight on the internal correction plane is to be hammered or glued, the laser dot has to be placed on the line **in the weight placement location**. For hammered weights the dot is to intersect with the line on the rim edge, as presented in fig. 7.1a. In case of adhesive weights the dot is to be intersected in the gluing position, as presented in fig. 7.1b.

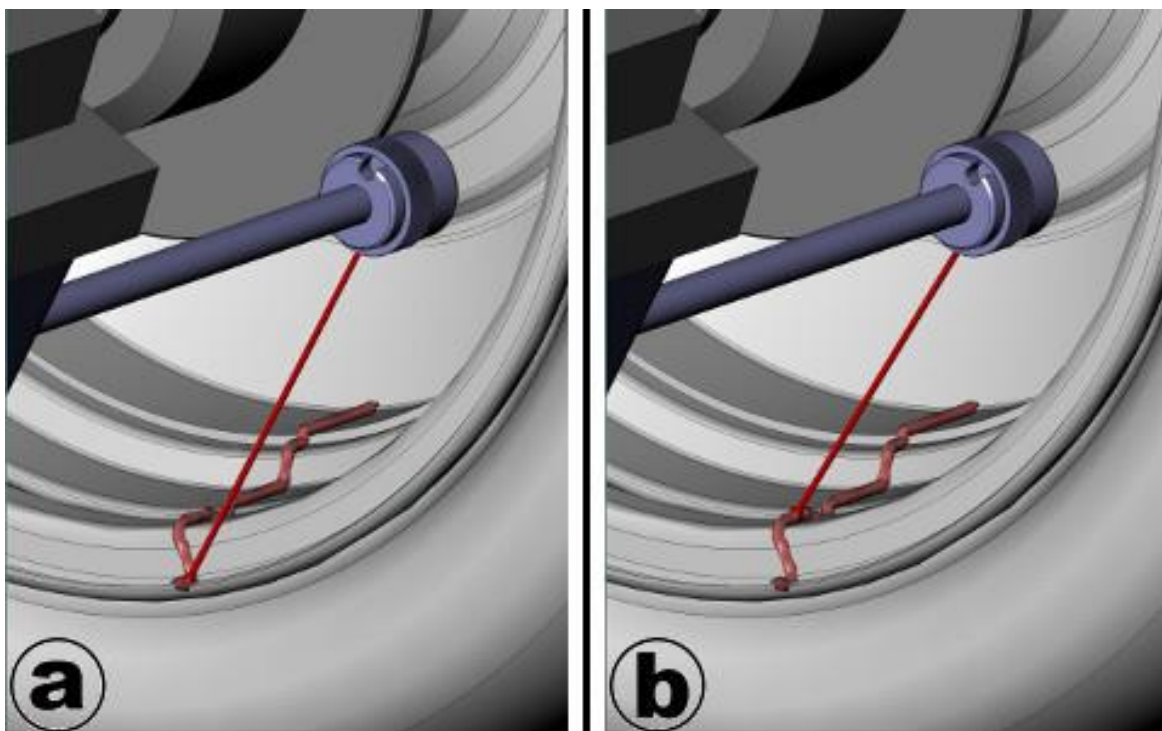

Fig. 7.1 Positioning the laser dot with respect to the laser line of the adjuster for:
a) hammered weights b) adhesive weights



ATTENTION: For the motorcycle mode, the dot is always to be positioned on the line like for adhesive weights (fig. 7.1b), regardless of whether weight placement mode 6 or 7 is selected. Weight position for mode 7 is evaluated according to input width parameter and is always in the middle of the rim base.



ATTENTION: If it is impossible to measure distance from the machine to the wheel, use a centimetre tape measure, subtract 2.5cm from the result, multiply by 4 and input the result using *Plus* and *Minus* keys on the keyboard.

$$L = (x \text{ cm} - 2.5\text{cm}) * 4$$

7.1 Working with adjuster with weight placement mode selected

Selecting the weight placement mode has been described in chapter 6.4.2. If it is selected before using the adjuster, the *ALU* caption on the icon (4 in fig. 6.3) changes its colour from white to black. After moving the cursor to distance or diameter and drawing the adjuster out, both parameters change their values according to the adjuster's current laser dot position. For all weight placement possibilities from table 6.2, weight placement position should be determined as described in the beginning of chapter 7 and as illustrated in fig. 7.1. After setting the laser dot on the line in the planned weight placement location the adjuster is to be left in such position for approximately 2 seconds until the machine generates a short signal indicating that the measurement result has been saved. For weight placement modes 1, 2, 3, 6 and 7 put the adjuster back to its original position¹. The cursor will automatically relocate to the width icon, so the user can set this parameter before starting the imbalance measurement. If the ultrasonic sensor is activated, it will measure the width of the wheel during hood closing for the above mentioned weight placement modes.

For weight placement modes 4 and 5 from table 6.2 (adhesive weight placed inside the rim of a car wheel), the ultrasonic sensor does not operate, because width is evaluated using the adjuster. The adjuster has two modes of operation, which can be set in the machine settings section as described in chapter 6.3.2:

- ▲ *Adjuster* mode,
- ▲ *EASY* mode.

Two methods have been provided for the convenience of the operator so that one can choose most handy way to select weight position inside the rim – either using the laser dot and line or directly under the handle's disc.

7.1.1 *Adjuster* mode

In the *Adjuster* mode, the operator has the possibility to accurately point the adhesive weight location inside the rim for external (right) correction plane. To indicate this point, right after the machine saves the first adjuster measurement (as described in chapter 7.1) and signals it with a short sound, one should **without putting the adjuster back to its original position** pull it out further into the rim until the desired weight location is reached. Doing so invokes value changes to diameter and width parameters with each adjuster position change. To correctly point the new weight location inside the rim, move the adjuster so that the laser dot is at the very end where it is still possible to glue the adhesive weight behind stokes. Subsequently, align the dot with the laser

¹ If *EASY* mode is activated, the adjuster should be put to its original position after the first draw out for all weight placement modes.

line and leave the adjuster in this position for approximately 2 seconds until the machine saves the measurement, signalling it with a short sound. Finally, when the second phase of adjuster measurement is over, put the adjuster back to its original position.



ATTENTION: While the adjuster performs the second measurement described above, width of the wheel cannot be less than 2 inches. This is the reason width is displayed in red when the value is below 2 inches and if the operator tries to save such value, the machine generates an error signal and does not permit saving such result.

After completing the imbalance measurement and when the machine displays imbalance values, to glue adhesive weights using the adjuster rotate the wheel so that the dot on the right side of the wheel on the screen – for the wheel displaying mode – is at the bottom and changes its colour from yellow to red, or – for the simplified displaying mode – both arrows point inwards on the imbalance value and the bottom frame changes its colour from black to red. When the wheel is in the described position, move the adjuster inside the wheel until the machine generates 5 short, quick signals and on the screen – depending on the displaying mode – a second yellow frame appears around the red frame for the simplified mode (fig. 7.2a), or a yellow frame around the imbalance value appears for the wheel displaying mode (fig. 7.2b). Finally, position the laser dot on the line, clean the area pointed by the dot and place an adhesive weight of appropriate value where the laser dot points.

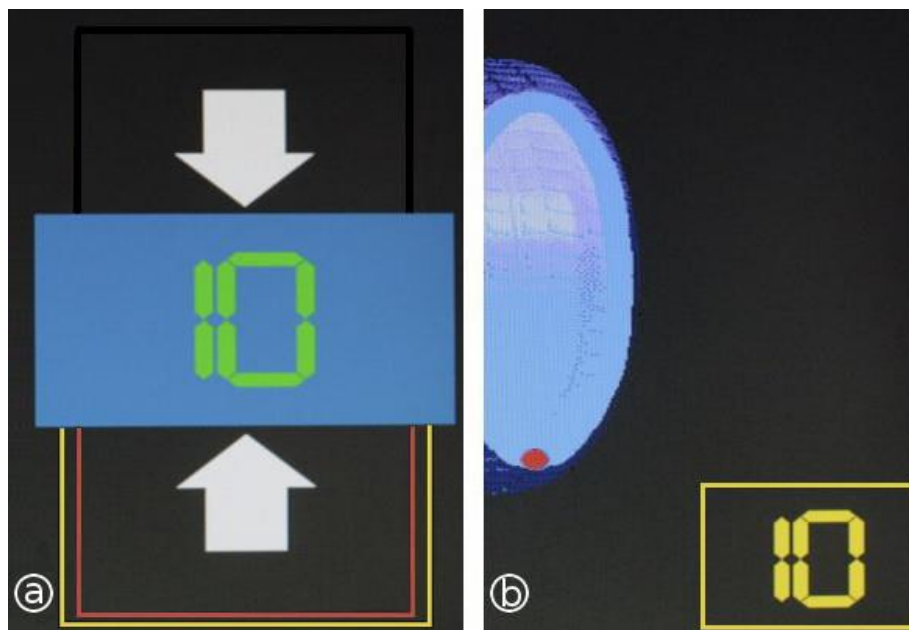

Fig. 7.2 Part of the screen with the adjuster positioned in adhesive weight placement location
a: for simplified displaying mode b: for wheel displaying mode

7.1.2 EASY mode

EASY mode is an alternative for machine operators who do not want to operate the adjuster while designating an adhesive weight location inside the wheel for external (right) correction plane. For weight placement modes 4 and 5 from table 6.2, a caption titled “EASY” appears on the icon (fig. 7.3) for pointing out that this option has been selected in the machine settings section. In this operating mode, adhesive weights are placed **UNDER THE HOLDER’S DISC**, as presented in fig. 7.4.



Fig. 7.3 EASY caption indicating the chosen adjuster operation mode

When using the adjuster, after the first measurement (distance and diameter) put it back to its original position. The machine calculates width between both weights (for left and right planes) of the balanced wheel automatically due to the fact that the weight is glued under the holder's disc. After completing the imbalance measurement and when the machine displays imbalance values, to glue adhesive weights using the adjuster rotate the wheel so that the dot on the right side of the wheel on the screen – for the wheel displaying mode – is at the bottom and changes its colour from yellow to red, as presented in fig. 7.5a, or – for the simplified displaying mode – both arrows point inwards on the imbalance value and the bottom frame changes its colour from black to red, as shown in fig. 7.5b. When the balanced wheel is positioned in described manner, clean the area under the holder's disc and place an adhesive weight of appropriate value like presented in fig. 7.4.

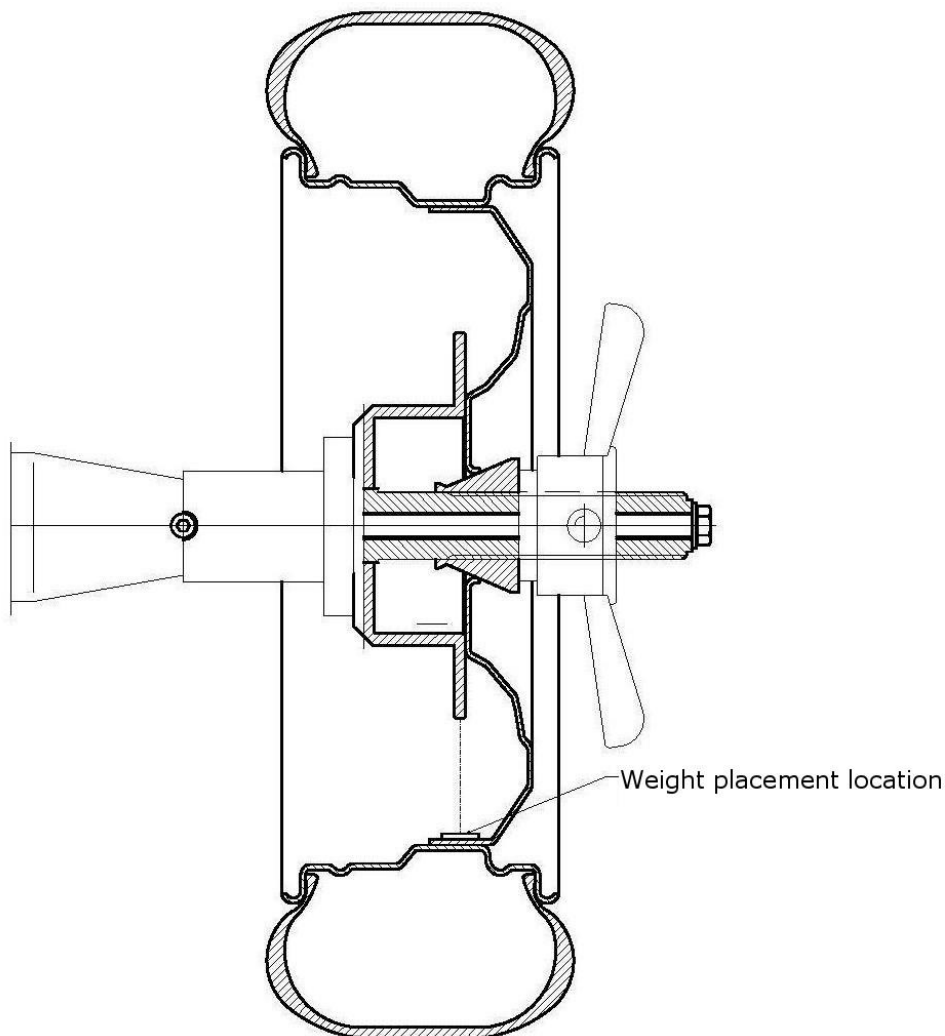

Fig. 7.4 Weight placement location for adjuster's EASY mode.

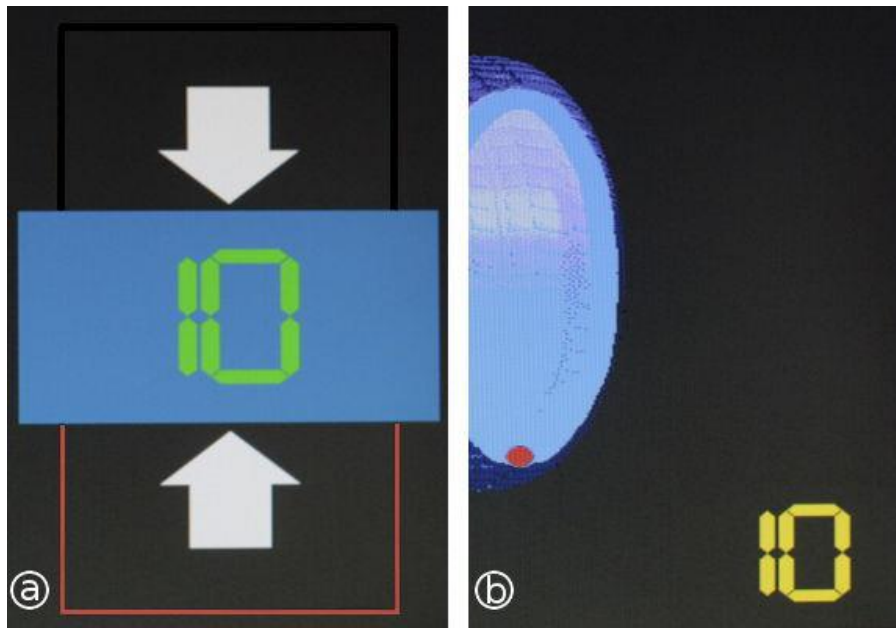

Fig. 7.5 Part of the screen when operating in EASY mode
 a: for simplified displaying mode b: for wheel displaying mode

7.2 Automatic weight placement selection

If before starting adjuster measurement the weight placement mode is not selected or the *Stop* button is pressed (and – if lector is available and activated – machine generates a “Clear” message), when the adjuster is pulled out the automatic weight placement selection is initiated. The machine, according to the way the operator uses the adjuster, can determine whether the external (right) correction plane will be balanced with weights glued inside the wheel or outside on the external surface.



ATTENTION: Automatic weight placement selection works only if the adjuster is operating in the *Adjuster* mode. *Easy* mode does not provide this option. For more details read chapter 7.2.1.

After moving the cursor to distance or diameter icon and drawing the adjuster out, a question mark appears on the weight placement icon’s left side as presented in fig. 7.6. It indicates initiation of the adjuster measurement’s first phase and automatic weight placement selection.

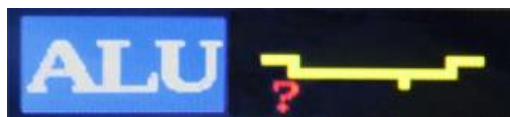

Fig. 7.6 The weight placement icon after first adjuster pull out
 for the automatic weight placement selection.



ATTENTION: Apart from the ALU icon, diameter will also change into a red question mark. It is caused by **true actual diameter values** measured by the adjuster. As long as it is uncertain if the weight is to be hammered or glued, the machine is not capable of determining the wheels’ nominal diameter.

After setting the laser dot and the line in weight placement location and waiting approximately 2 seconds until the machine saves the result, a second question mark appears (fig. 7.7a). It means that

the second phase of adjuster measurement has started, which defines the location of the weight for the external (right) imbalance correction plane. If the weight is to be placed on the outer part of the rim and not inside, the adjuster should be put back in its original position. Afterwards, the cursor will be relocated to the weight placement icon and the machine will suggest the first mode from table 6.2.



WARNING: Due to selecting the weight location on the outer side of the wheel, there is no possibility to change to weight placement modes with the weight inside the rim for the external (right) correction plane. Only modes 1, 2 and 3 from table 6.2 are available. To change it and have the ability to select any weight placement mode, press the *Stop* key in order to clear saved results. If the lector option is available and activated, the machine will generate a “Clear” message.

If the weight is to be placed inside the rim, then after the first phase move the adjuster inside the rim. This will relocate the question mark in the weight placement icon to the left (fig. 7.7b), and the width parameter will start changing with further adjuster movement into the rim. After aligning the laser dot with the laser line in the desired weight location, wait approximately 2 seconds for the machine to save the result. After putting the adjuster back to its original position, the cursor will be relocated to the weight placement icon and the machine will suggest mode 4 from table 6.2.

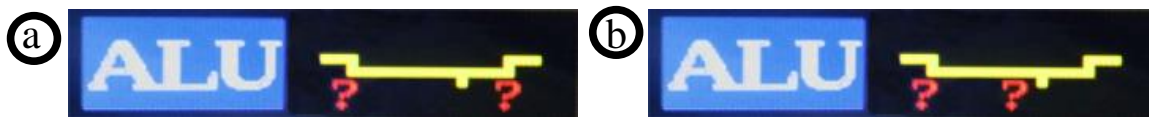

Fig. 7.7 Weight placement icon view a: beginning of second phase
b: when continuing adjuster movement into the rim.



WARNING: Due to selecting the weight location inside the wheel, there is no possibility to change to weight placement modes with the weight on the outer side. Only modes 4 and 5 from table 6.2 are available. To change it and have the ability to select any weight placement mode, press the *Stop* key in order to clear saved results. If the lector option is available and activated, the machine will generate a “Clear” message.

7.2.1 EASY mode and automatic weight placement selection

If *EASY* mode is activated, automatic weight placement selection does not function. It is caused by automatic width calculation when the weight is placed under the holder’s disc. That is why there is no need to insert the adjuster inside the rim for the second time.

When the first phase of adjuster measurement is initiated, 3 question marks are displayed on the weight placement icon as presented in fig. 7.8. After determining weight placement for the internal (left) imbalance correction plane (described in the beginning of chapter 7) and saving the result, adjuster is to be put back to its original position. Afterwards, the cursor is automatically placed on the weight placement icon. To select the desired mode, use the *Plus* or *Minus* key.

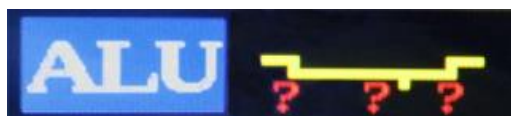

Fig. 7.8 Weight placement icon view after pulling the adjuster out in EASY mode.

8. User memory

Wheel balancing machines are equipped with internal memory allowing operators to save four different wheel parameters. To read previously saved or save current wheel parameters in one of the memory banks, press the *Memory* button (18 in fig. 2.2) in the balancing program screen. A new screen, presented in fig. 8.1, will appear on the LCD display. Each of the four memory banks has its own name, limited to 14 characters, which can be changed according to the operator's need.

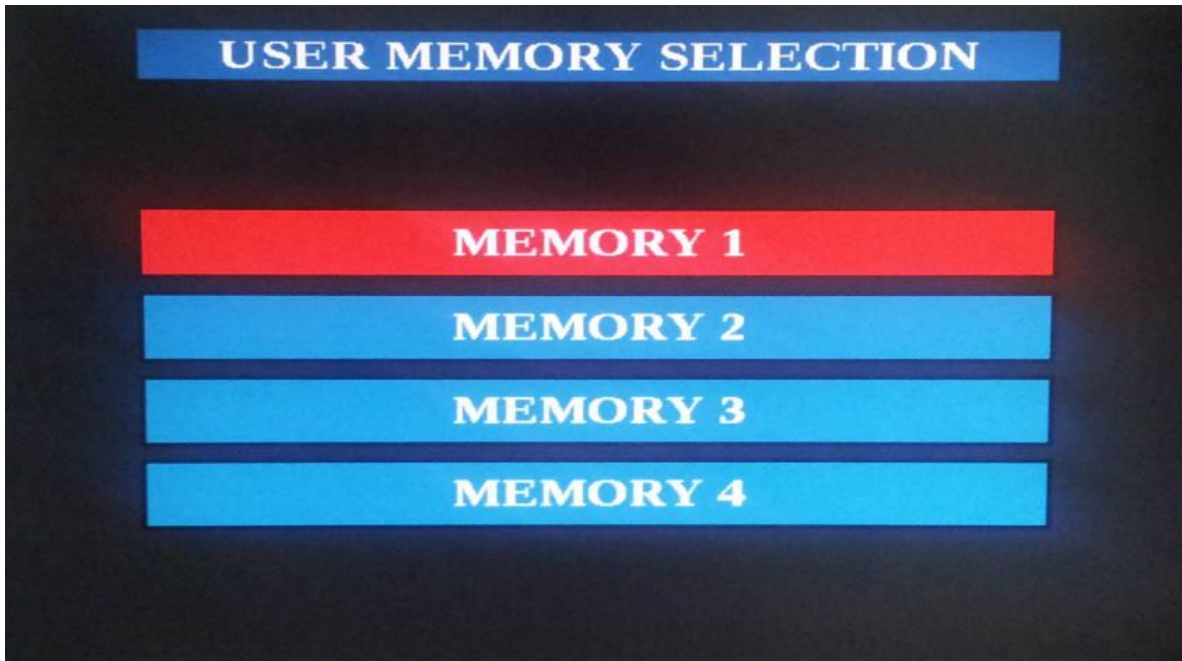

Fig. 8.1 User memory screen.

Each memory bank has its submenu, which is activated by moving the cursor to one of the banks and pressing the *Enter* key. Right above the first memory bank a small menu appears, presented in fig. 8.2. It is used for either reading memory, saving to memory or editing the memory bank's name.

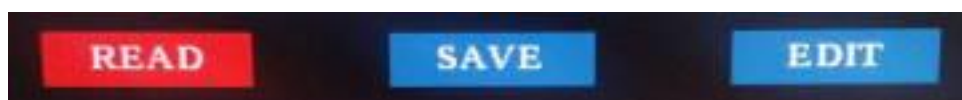

Fig. 8.2 Memory bank's submenu

8.1 Memory reading

To read previously saved wheel parameters select the desired memory bank and press *Enter* to activate the submenu. Afterwards, move the cursor to the *Read* position using either the up and down arrow keys or *L* and *R* keys (if the cursor's position has not been changed, it is by default set to "Read"). After confirming with the *Enter* key, the machine brings the balancing program screen back with all the parameters set to values read out from the selected memory bank. If the lector option is available and activated, the machine signals the reading with a "Memory reading" message.



WARNING: Memory reading is an irreversible operation! It replaces previous parameters and there is no possibility of recovering these parameters other than inputting them again.

8.2 Saving to memory

To save newly provided wheel parameters select the desired memory bank, which can have its data replaced, and press *Enter*. Afterwards, move the cursor to the *Save* position using either the up and down arrow keys or *L* and *R* keys and press *Enter* again to approve the option. The machine brings the balancing program screen back. If the lector option is available and activated, the machine signals the reading with a “Memory record” message.

8.3 Editing the memory bank name

By default, all banks have the same name followed by a different number from 1 to 4. For the operator’s convenience, there is a possibility of changing the name of each memory bank for easier distinction between them. To do so, select the desired memory bank and press *Enter* to activate the submenu. Afterwards, move the cursor to the *Edit* position using either the up and down arrow keys or *L* and *R* keys and press *Enter* again. At that moment the menu element becomes divided into 14 elements, each representing a single character. To move the blue cursor, set on the first element by default, use the *L* and *R* keys to shift the cursor left or right, respectively. To change a character simply use the *Plus* and *Minus* keys. To clear the field (and insert a “space”) press the *Stop* button. If the new name is ready, press the *Memory* key to approve of the performed changes or press *Escape* to cancel them. After entering the editing mode, a small description of above described keys’ function is presented for the operator.

9. Diagnostics and fault detection

FAILURE	POSSIBLE CAUSES	SOLUTION
The balancing machine does not generate sounds, the power button is not lit, the monitor does not work	Electric system failure – no electric supply	Check the fuse, check if all electrical connections are not worn out
Unstable, incorrect results of the adjuster measurement	The photo coupler's controller plate is damaged, broken pieces on code bar, damaged potentiometer	Blow the photo couplers with dry air, change the code bar, change the potentiometer
The keyboard's buttons do not activate all functions	Poor contact of wires connecting the keyboard to the indicator's plate and indicator's plate to the main board, damaged keyboard	Check all connections, replace the keyboard
Incorrect indications for different wheel mountings	The spindle and/or the cone are dirty, the centralizing cone is worn out, the nut is broken, the holder is broken or hit	Clean all dirty elements, replace the cone, replace the nut, replace the holder

Contacting our authorised service is always advised.

UNI -TROL

MANUFACTURING PLANT & STORE

int. 117

<http://www.unitrol.com.pl>

8349014 int. 115

UNI - TROL Co. Ltd.

ul . Estrady 56 , 01 - 932 Warsaw, POLAND
tel.(+4822) 8179422 or 8349013 or 8349014

fax(+4822) 8179422 or 8349013 or

e-mail: office@unitrol.pl ;

office@unitrol.pl ;

WHEEL BALANCING MACHINES
TYRESHOPS

RIM STRAIGHTENING MACHINES

TYRE CHANGERS

EQUIPMENT FOR

Statistic no. : 008132994
PL527020524600000

EC VAT no. : PL5270205246

Register no. : KRS 0000111731

EORI no. :

Account : for EURO : BZ WBK SA no. PL 62 1090 1014 0000 0000 0303 1619

(swift code: WBK PPL PP XXX)



CE Conformity Declaration

in accordance with directives : 2006/42/EC, 2006/95/EC, 2004/108/EC

We : **Uni-trol Co. Ltd.**
Ul. Estrady 56
01-932 Warsaw
Poland

declare, under our exclusive responsibility, that the product

Wheel balancing machine

Electromechanical device

model TROLL 2351L

Serial number

concerned by this declaration, complies with all relevant requirements of the Machinery Directive:

- **Directive 2006/42/EC (safety machines),**

applicable in the essential requirements and relevant conformity assessment procedures, as well as on the essential requirements of the following directives:

- **Directive 2006/95/EC (the low voltage) ;**

- **Directive 2004/108/EC (the electromagnetic compatibility).**

In order to verification of compliance with the applicable legal regulations have been consulted harmonized standards and other normative documents:

PN-EN ISO 12100:2012P

Safety of machinery -- General principles for design -- Risk assessment and risk reduction

PN-EN 61000-6-3:2008P

Electromagnetic compatibility (EMC) -- Part 6-3: General standards -- Emission standard for environments: residential, commercial and light industrial

PN-EN 61000-6-4:2008P

Electromagnetic compatibility (EMC) -- Part 6-4: General standards -- Emission standard for industrial environments

PN-EN ISO 13857:2010P

Safety of machinery - Safety distances to prevent hazard zones being reached by upper and lower limbs

PN-EN 349+A1:2010P

Safety of machinery - Minimum gaps to avoid crushing of parts of the human body

PN-EN 60204-1:2010P

Safety of machinery -- Electrical equipment of machines -- Part 1: General requirements

PN-EN 61293:2000P

Marking of electrical equipment with ratings related to electrical supply -- Safety requirements

[PN-EN ISO 11554:2010P](#)

[Optics and photonics - Lasers and laser-related equipment - Test methods for laser beam power, energy and temporal characteristics](#)

PN-EN 60825-12:2008P

Safety of laser products - Part 12: Safety of free space optical communication systems used for transmission of information

PN-EN ISO 11201:2012P

Acoustics -- Noise emitted by machinery and equipment -- Determination of emission sound pressure levels at a work station and at other specified positions in an essentially free field over a reflecting plane with negligible environmental corrections

PN-EN ISO 11202:2012P

Acoustics -- Noise emitted by machinery and equipment -- Determination of emission sound pressure levels at a work station and at other specified positions applying approximate environmental corrections

PN-EN ISO 4871:2012P

Acoustics -- Declaration and verification of noise emission values of machinery and equipment

PN-EN 50419:2008P

Marking of electrical and electronic equipment in accordance with Article 11 (2) of Directive 2002/96/CE (WEEE)

PN-EN 61190-1-3:2008E

[Materials for connecting electronic components -- Part 1-3: Particular requirements for solders for electronic applications and solders with fluxes or without fluxes for soldering electronic components](#) .

PN-EN 61760-1:2006E

Surface mounting technology -- Part 1: Method qualification standard components for surface mount (SMD) (SMD)

The technical documentation of this device, referred to in point 1 of Annex VII A of the Machinery Directive, is located in the headquarters Uni-trol Ltd. (address as above) and will be made available to the competent national authorities for at least 10 years after the last piece.

The person responsible for the preparation of the technical documentation of the product and introducing changes in it, is MSc. Gregory Tworek - Member of the Board.

This EC Declaration of Conformity will be kept by the manufacturer of the product for 10 years from the date of produce the last unit and will available for market supervisory authorities for verification.

MSc. Gregory Tworek - Member of the Board.

Warsaw, 21.10.2013

.....

Signature